

DIPLOMA IN MECHANICAL ENGINEERING PROGRAMME (DMEN)
 EGR1174: ENGINEERING STATICS
 FINAL EXAMINATIONS: JANUARY 2020 SESSION

Instructions: This paper consists of **FOUR (4)** questions. Answer all **FOUR (4)** questions in the answer booklet provided. All questions carry equal marks.

Question 1

Determine the force in each member of the truss and state if the members are in tension or compression. Set $P_1 = 3 \text{ kN}$, $P_2 = 6 \text{ kN}$.

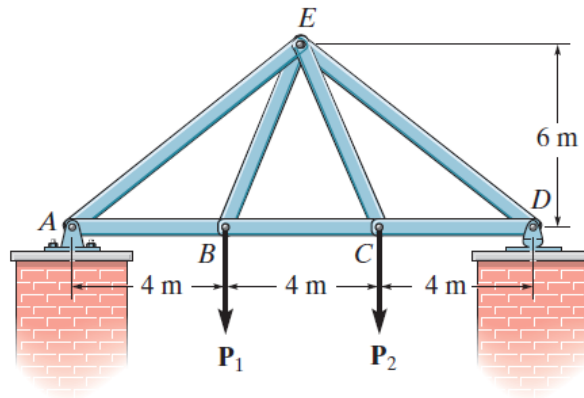

Figure Q1

(25 marks)

Question 2

- (a) The mine car and its contents have a total mass of 6000 kg and a center of gravity at G. If the coefficient of static friction between the wheels and the tracks is $\mu_s = 0.4$ when the wheels are locked, find the normal force acting on the front wheels at B and the rear wheels at A when the brakes at both A and B are locked. Does the car move?

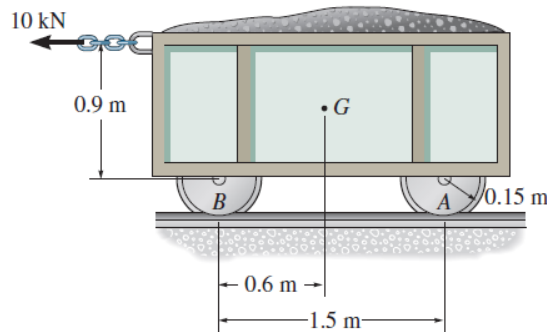

Figure Q2a

(12 marks)

- (b) The uniform 10-kg ladder rests against the smooth wall at B , and the end A rests on the rough horizontal plane for which the coefficient of static friction is $\mu_s = 0.3$. Determine the angle of inclination θ of the ladder and the normal reaction at B if the ladder is on the verge of slipping.

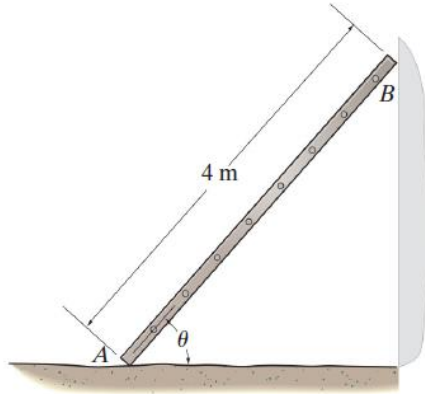

Figure Q2b

(13 marks)

Question 3

Determine the internal normal force, shear force, and moment at points E and F in the beam.

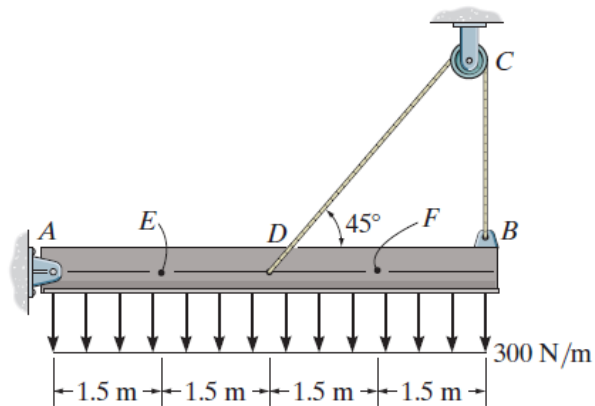

Figure Q3

(25 marks)

Question 4

- (a) The steel and aluminum plate assembly are bolted together and fastened to the wall. Each plate has a constant width in the z direction of 200 mm and thickness of 20 mm. If the density of A and B is $\rho_s = 7.85 \text{ Mg/m}^3$ and for C is, $\rho_{al} = 2.71 \text{ Mg/m}^3$, determine the location of the center of mass. Neglect the size of the bolts.

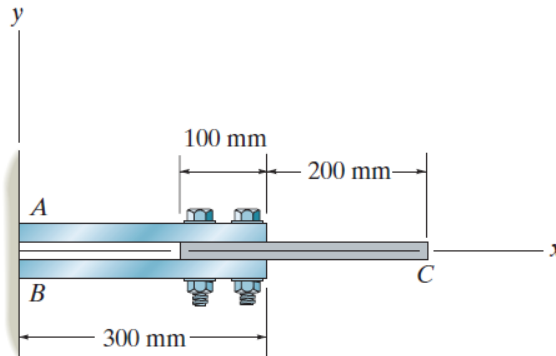

Figure Q4a

(9 marks)

- (b) Determine \bar{y} , which locates the centroidal axis x' for the cross-sectional area of the T-beam, and then find the moments of inertia $I_{x'}$ and $I_{y'}$.

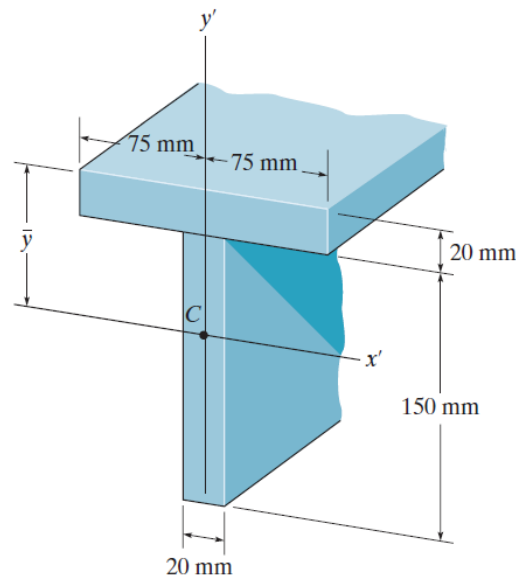

Figure Q4b

(16 marks)

-THEEND-