

**FINAL
ALTERNATIVE ASSESSMENT**

(COVER PAGE)

Session : April 2021

Programme : Diploma in Mechanical Engineering (DMEN)

Course : **EGR1174: Engineering Statics**

Date of Examination : 28 Wednesday 2021 (Wednesday)

Time : 8.00am – 10.15am Reading Time : Nil

Duration : 2 Hours 15 Minutes

Special Instructions :

This paper consists of **FOUR (4)** questions. Answer all **FOUR (4)** questions. All questions carry equal marks.

Material permitted : Non-Programmable Scientific Calculator

Materials provided : Formulae List

Examiner(s) : **Nur Hafizah Habideen**

Chief Moderator : Dennis Koh Mui Siang

This paper consists of 6 printed pages, including the cover page

DIPLOMA IN MECHANICAL ENGINEERING PROGRAMME (DMEN)
EGR1174: ENGINEERING STATICS
FINAL ALTERNATIVE ASSESSMENT: APRIL 2021 SESSION

Instructions: This paper consists of **FOUR (4)** questions. Answer all **FOUR (4)** questions. All questions carry equal marks.

Question 1

Figure Q1 shows a truss. Determine the force in each member of the truss in Figure Q1 and state if the members are in tension or compression. Given $P_1 = 30 \text{ kN}$ and $P_2 = 15 \text{ kN}$.

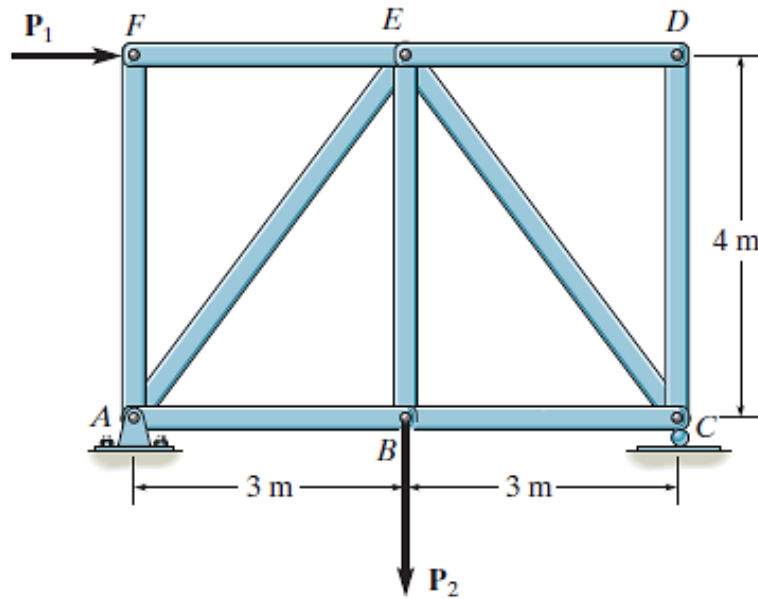

Figure Q1

(25 marks)

Question 2

Figure Q2 shows a pulley system. There are two pulleys with radius of 200 mm at point C and E. Point A and B are pin-connected.

- (a) Determine the support reaction at A and B.

(17 marks)

- (b) Determine the internal forces at point J.

(8 marks)

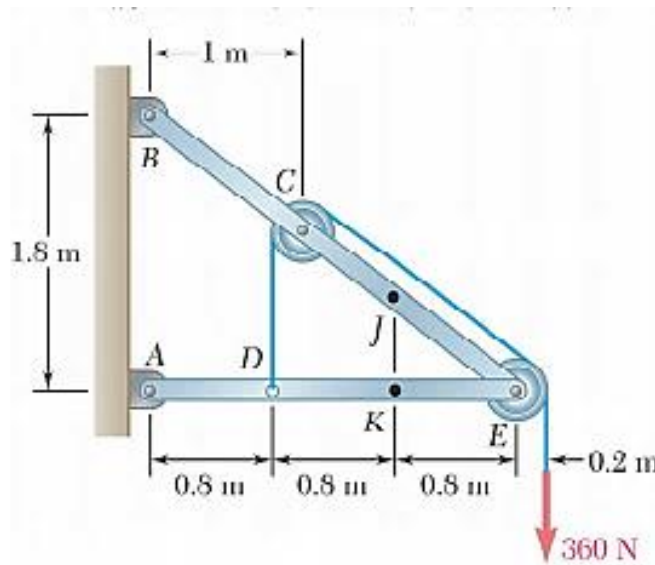

Figure Q2

Question 3

- (a) Figure Q3(a) shows a brake system that is used to stop a wheel from rotating. The wheel is subjected to a couple moment $M_0 = 360 \text{ Nm}$ counterclockwise. Determine the minimum force P , if the coefficient of static friction between the wheel and the block is $\mu_s = 0.6$.

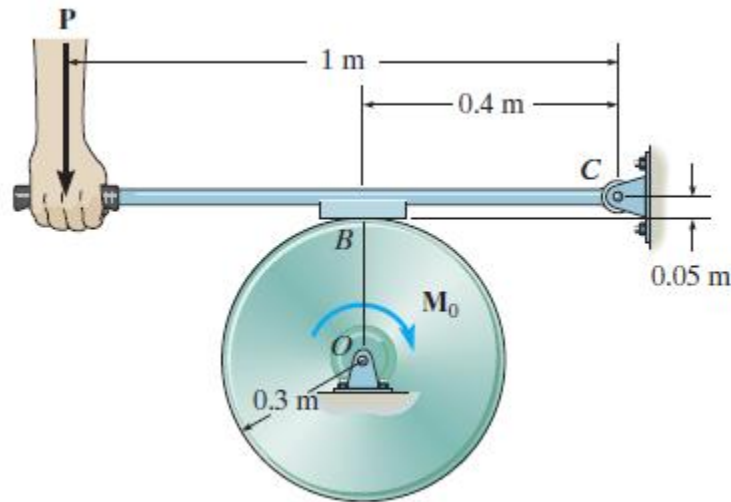

Figure Q3(a)

(12 marks)

- (b) Figure Q3(b) shows a car of mass $2 Mg$ and center of mass at G . Both the front and rear brakes are locked. The coefficient of static friction, μ_s , is 0.3. Determine the towing force F required to move the car.

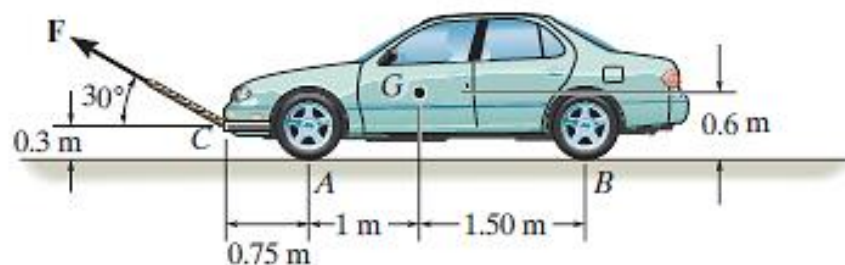

Figure Q3(b)

(13 marks)

Question 4

- (a) Determine the x -coordinate of centroid for length of the sheet steel shows in Figure Q4(a). The dimensions are indicated at the center thickness of each segment.

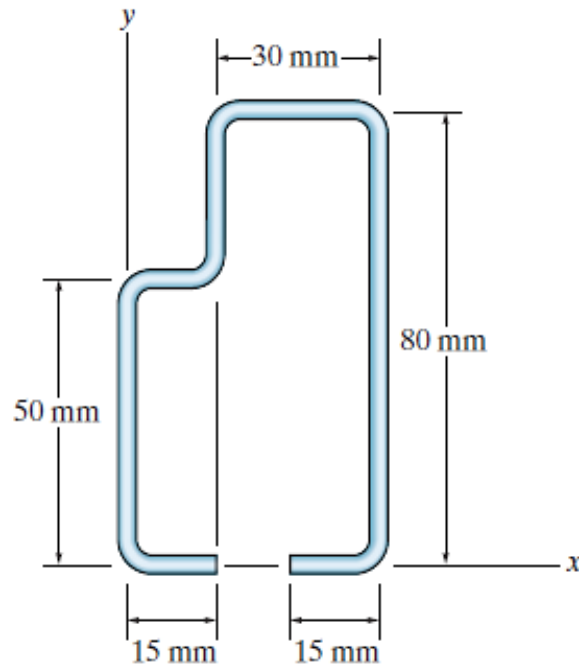

Figure Q4(a)

(9 marks)

- (b) Identify the y -coordinate of centroid for the cross sectional area shown in Figure Q4(b) and then determine the moment of inertia about the x' axis.

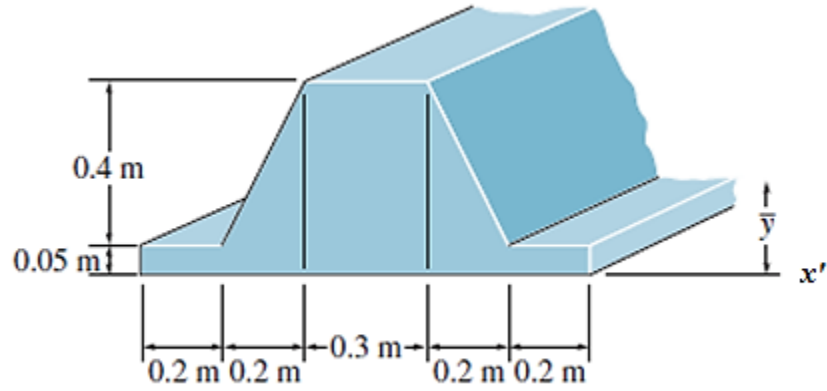

Figure Q4(b)

(16 marks)

~THE END~

EGR1174 (F)/ April2021 Session/formatted