

**FINAL
ALTERNATIVE ASSESSMENT**

(COVER PAGE)

Session : August 2020

Programme : Diploma in Electrical & Electronic Engineering (DEEI)
Diploma in Mechanical Engineering (DMEN)

Course : EGR1185/EGR1175: Engineering Drawing

Date of Examination : 12 December 2020 (Saturday)

Time : 8.00am – 10.20am Reading Time : Nil

Duration : 2 Hours 20 Minutes

Special Instructions :

This paper consists of **FOUR (4)** questions. Answer **ALL** questions. All questions carry equal marks.

Material permitted : Non-Programmable Scientific Calculator

Materials provided : Nil

Examiner(s) : Phua Chin Lai

Chief Moderator : Tham Chan Seng

This paper consists of 5 printed pages, including the cover page

DIPLOMA IN ELECTRICAL & ELECTRONIC ENGINEERING PROGRAMME (DEEI)
DIPLOMA IN MECHANICAL ENGINEERING PROGRAMME (DMEN)
EGR1175 / EGR1185: ENGINEERING DRAWING
FINAL ALTERNATIVE ASSESSMENT: AUGUST 2020 SESSION

Instructions: This paper consists of **Four (4)** questions. Answer **ALL** questions. All questions carry equal marks. All drawings are to be drawn in full size unless otherwise stated. All dimensions are not required unless the question explicitly asks for them.

NOTE: All dimensions are given in mm.

Question 1

Draw the following views of the object shown in Figure Q1 with 1st Angle Projection.

- (a) Front view as given by arrow F
- (b) Right End view
- (c) Plan view

(25 marks)

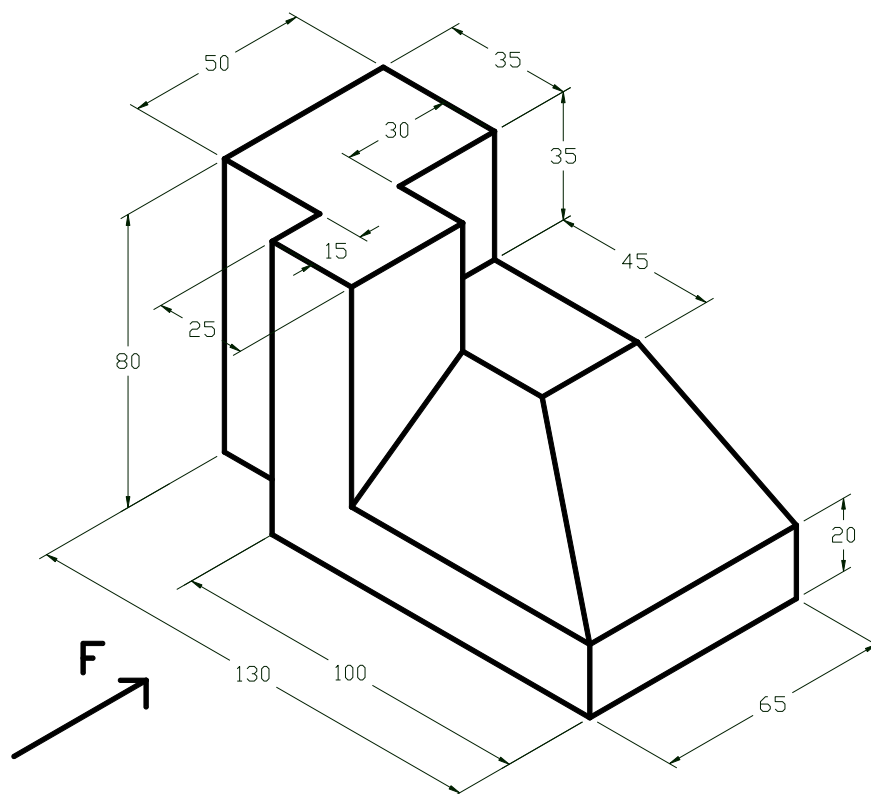
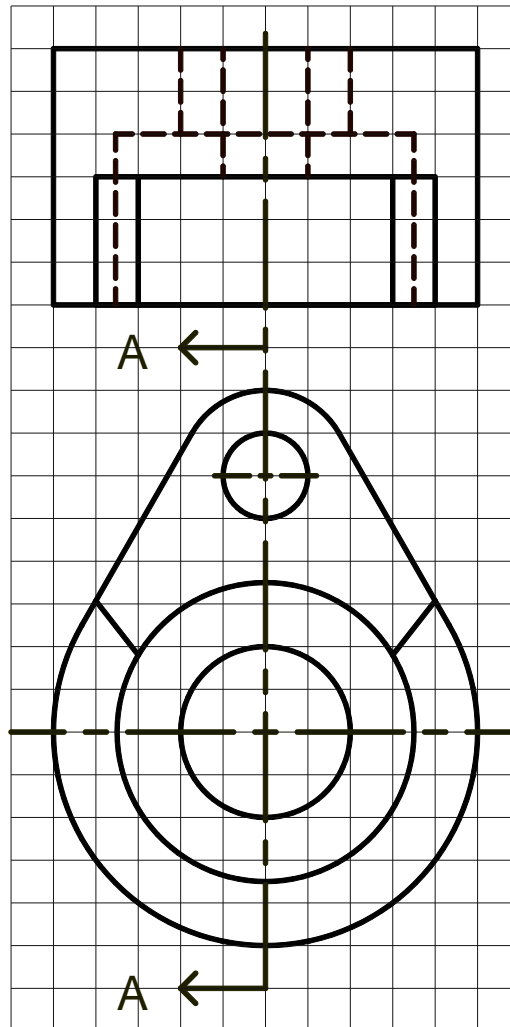

Figure Q1

Question 2

- Given the front and plan views in Figure Q2, draw the following views in 3rd Angle Projection:
- (a) the front view as given (4 marks)
 - (b) a top view as given (2 marks)
 - (c) a sectional view A-A (19 marks)



1 grid = 1 cm

Figure Q2

Question 3

Draw oblique cabinet projection of the following object (Figure Q3, presented in 3rd angle projection) receding to right.

(25 marks)

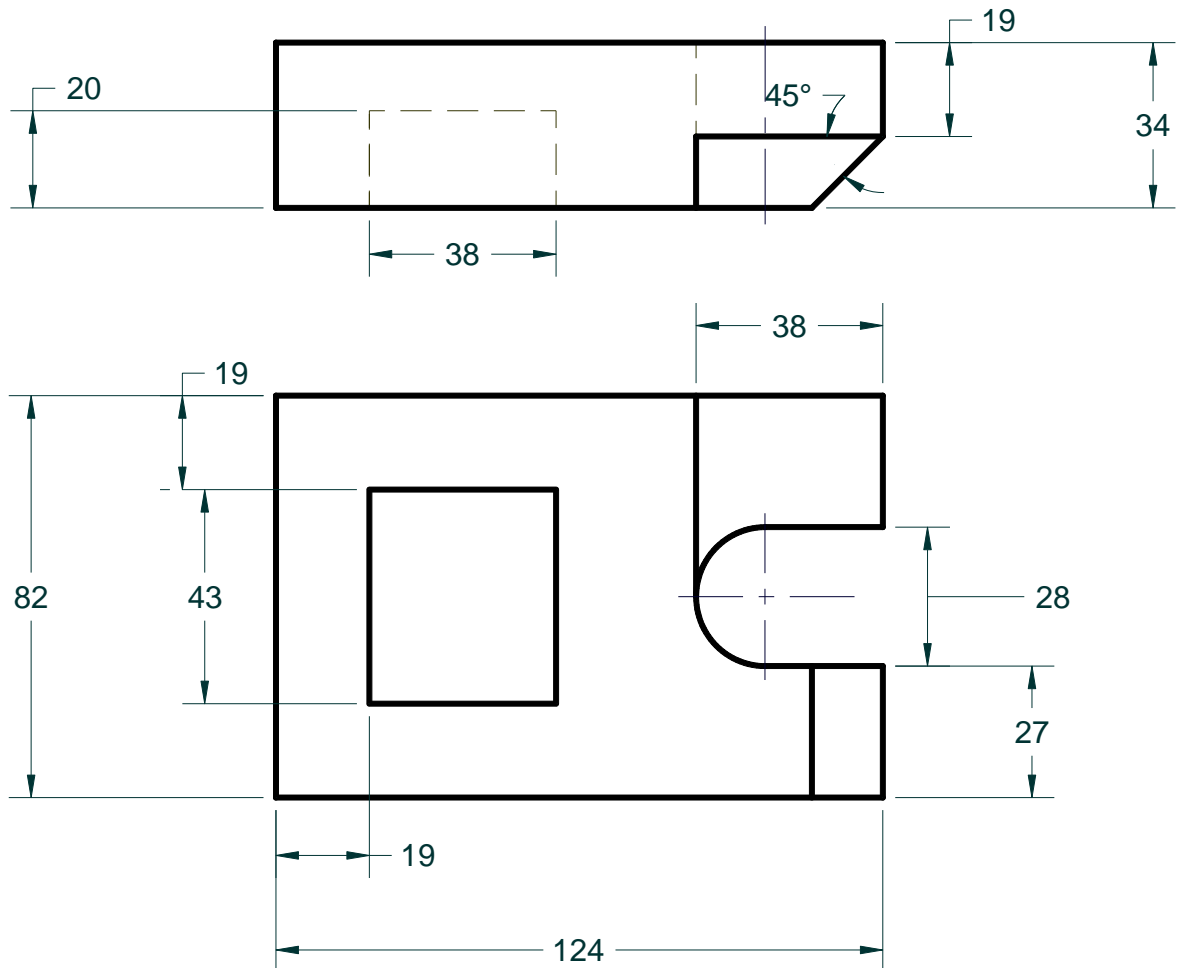

Figure Q3

Question 4

Two views of an oblique rectangular pyramid are shown in Figure Q4. Develop its lateral surface.

(25 marks)

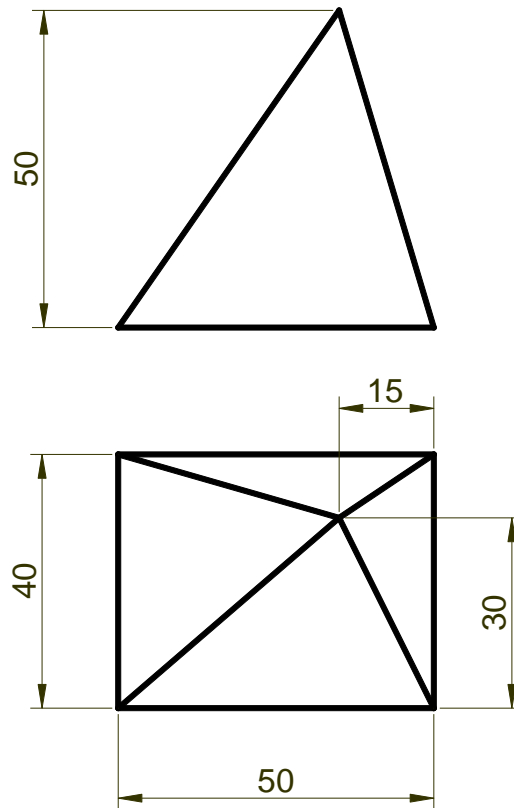

Figure Q4

~THE END~

EGR1175/EGR1185 (F) / August 2020 Session/ formatted