

**FINAL**  
Examination Paper

(COVER PAGE)

Session : August 2019

Programme : Diploma In Mechanical Engineering (DMEN)

Course : EGR2180 : Fluid Mechanics 2

Date of Examination : December 14,2019 (Saturday)

Time : 2:00 pm – 4:00 pm Reading Time: Nil

Duration : 2 Hours

Special Instructions :

This paper consists of **SIX (6)** questions. Answer any **FOUR (4)** questions in the answer booklet provided. All questions carry equal marks.

Materials permitted : Non-Programmable Calculator

Materials provided : Nil

Examiner (s) : Nur Hafizah Habideen and Teow Hsien Loong

Moderator : Dr Fauziah Jerai Junaidi

*This paper consists of 6 printed pages, including the cover page.*

DIPLOMA IN MECHANICAL ENGINEERING PROGRAMME (DMEN)  
EGR2180: FLUID MECHANICS 2  
FINAL EXAMINATIONS: AUGUST 2019 SESSION

**Instructions:** This paper consists of **SIX (6)** questions. Answer any **FOUR (4)** questions in the answer booklet provided. All questions carry equal marks.

**Question 1**

- (a) Two reservoirs *A* and *C* having a difference of level of 15.5 m are connected by a pipeline *ABC* with the elevation of point *B* being 4 m below the level of water in reservoir *A*. The length *AB* of the pipeline is 250 m, the pipe being made of mild steel have a friction coefficient  $f_1$ , while the length *BC* is 450 m, having made of cast iron have a friction coefficient  $f_2$ . Both the pipes have a diameter of 20 cm. A partially closed valve is located in the length *BC* at a distance of 150 m from the reservoir *C*. If the flow through the pipeline is  $0.05 \text{ m}^3/\text{s}$ , the pressure head at *B* is 0.5 m and the head loss at the valve is 5 m, find the friction coefficient  $f_1$  and  $f_2$ . Refer to Figure Q 1 (a) below and account for all losses. Take  $g = 9.81 \text{ m/s}^2$ .

(15 marks)

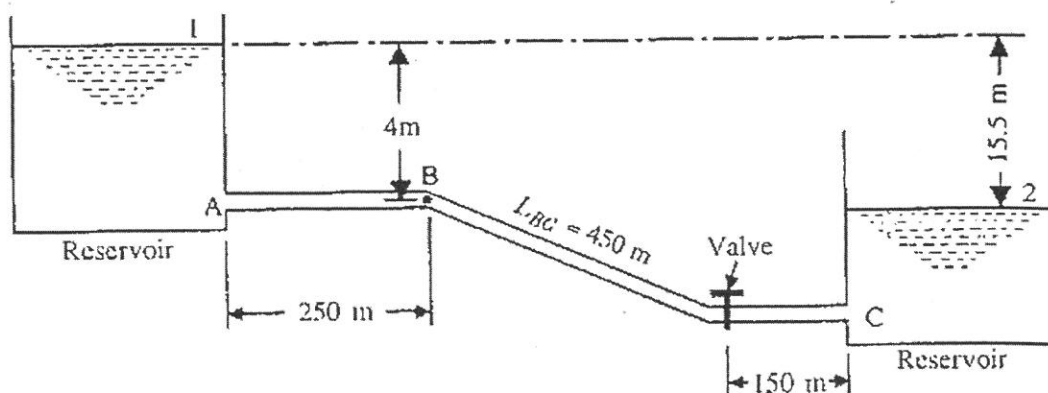

Figure Q1 (a)

- (b) A 50 cm diameter and 100 m long pipeline carrying  $0.5 \text{ m}^3/\text{s}$  discharge is fitted with a valve at the downstream end. Taking sonic velocity as  $1430 \text{ m/s}$ , determine;
- (i) The critical time for valve closure. (2 marks)
  - (ii) The rise in pressure caused within the pipe due to valve closure in 1 second. (4 marks)
  - (iii) The rise in pressure caused within the pipe due to valve closure instantaneously. (4 marks)

**Question 2**

- (a) Calculate the velocity and Mach number of a projectile, if the Mach angle is  $42.5^\circ$  and the temperature of air is  $5^\circ\text{C}$ . Take  $R$  as  $297 \text{ J/kg}\cdot\text{K}$  and  $k = 1.4$ . (10 marks)
- (b) A 900 mm diameter steel pipe carries water at the rate of  $1.5 \text{ m}^3/\text{s}$ . The pipe wall has a thickness of 1 cm. The elastic modulus of steel is  $2 \times 10^{11} \text{ N/m}^2$  and the bulk modulus of water is  $2.1 \times 10^9 \text{ N/m}^2$ . Determine the increase in pressure if the valve at the end of 3.5 km long pipe line is closed in 3.5 seconds. Take  $\rho_{\text{water}} = 1000 \text{ kg/m}^3$ . (10 marks)
- (c) Briefly explain the cause of water hammer. State **ONE (1)** way to reduce the effect of water hammer. (5 marks)

**Question 3**

- (a) The pressure at the inlet of a pipeline is 4000 kPa and the pressure drop is 200 kPa. The pipeline is 1.5 km long. If 100 kW is to be transmitted over this pipeline, find the diameter of the pipe and efficiency of transmission. Take  $f = 0.024$ ,  $g = 9.81 \text{ m/s}^2$  and  $\rho_{\text{water}} = 1000 \text{ kg/m}^3$ . (15 marks)
- (b) Water has a velocity of 5 m/s as it flows along the rectangular channel shown in Figure Q3 (b) below. If the depth of the flow is 3 m, classify the flow. What is the same specific energy for the flow and velocity? Take  $g = 9.81 \text{ m/s}^2$ .

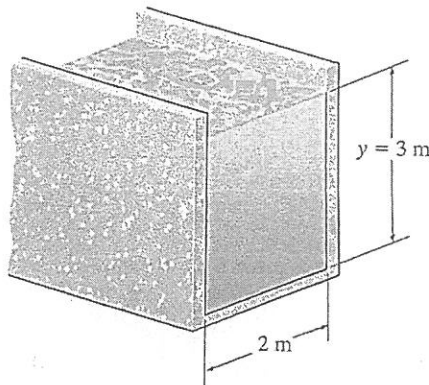

Figure Q3 (b)

(10 marks)

## Question 4

- (a) A jet airplane is propelled at a velocity of 1000 km/h through the air in which the atmospheric pressure is  $88.3 \text{ kN/m}^2$ . The temperature is  $-5^\circ\text{C}$  and the wind velocity is negligible. Calculate the pressure intensity, the temperature, the density of air at the stagnation point on the nose of the jet, and determine its Mach number. Take  $R = 290 \text{ Nm/kg}\cdot\text{K}$  and  $k = 1.4$ .  
(13 marks)
- (b) The blades on an impeller of the axial-flow water pump in Figure Q4 (b) rotate at 1000 rev/min. if the pump is required to produce a flow of  $0.2 \text{ m}^3/\text{s}$ , determine the required initial blade angle  $\beta_1$  so that the pump runs efficiently. Also, if  $\beta_2 = 70^\circ$ , find the average torque that must be applied to the shaft of the impeller and the average power output of the pump. The average open cross-sectional area through the impellers is  $0.03 \text{ m}^2$ .

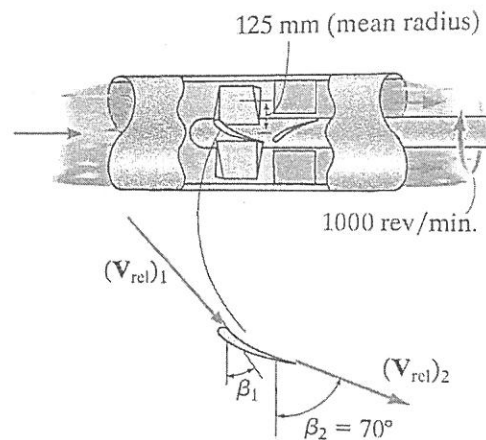

Figure Q4 (b)

(12 marks)

## Question 5

- (a) The sluice gate in Figure Q5 (a) is partially open in a 2-m wide channel, and water passing under the gate forms a hydraulic jump. At the low level, just before the jump, the water depth is 0.2 m, and the flow is  $1.30 \text{ m}^3/\text{s}$ . Determine the depth farther downstream and also the head loss across the jump. Take  $g = 9.81 \text{ m/s}^2$ .

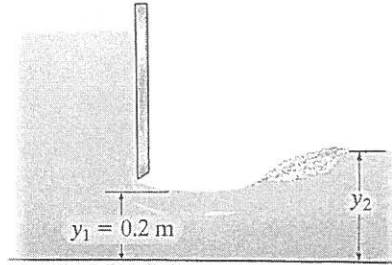

Figure Q5 (a)

(10 marks)

- (b) In rectangular channel flow, show that for minimum specific energy, the corresponding critical depth is given by,

$$y_c = \left( \frac{q^2}{g} \right)^{\frac{1}{3}}$$

(10 marks)

- (c) Describe the difference between uniform flow, rapidly varied flow and gradually varied flow with the aid of diagram

(5 marks)

**Question 6**

- (a) A Francis turbine is supplied with  $5.1 \text{ m}^3/\text{s}$  with average head of 20 m. The runner diameter is 3.6 m at inlet and 2.4 m at outlet. The inlet vane angle is  $120^\circ$  and the turbine has radial discharge at 15 m/s with wheel breadth is constant. If the hydraulic and overall efficiencies are 90% and 80% respectively, find the power produced by the turbine and its speed. Please refer to Figure Q6 (a). Take  $g = 9.81 \text{ m/s}^2$ .

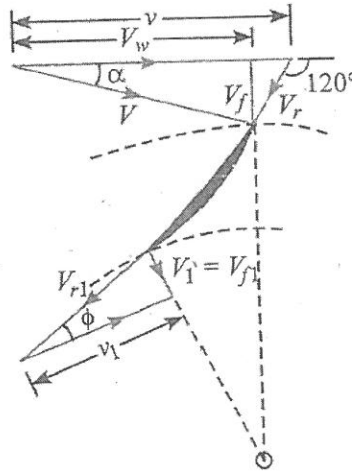

Figure Q6 (a)

(15 marks)

- (b) A rough timber flume ( $n = 0.012$ ) in the form of an equilateral triangle (apex down) of 1.2 m sides is laid on slope of 0.01. Calculate the uniform flow rate which occurs at a depth of 90 cm. Refer to Figure Q6 (b).

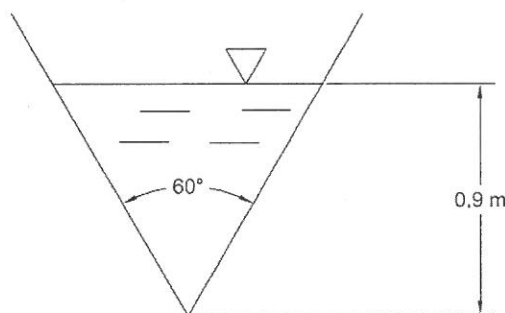

Figure Q6 (b)

(10 marks)

**-THE END-**