

FINAL

ALTERNATIVE ASSESSMENT

(COVER PAGE)

Session : April 2020

Programme : Diploma In Electrical and Electronic Engineering (DEEI)
Diploma In Mechanical Engineering (DMEN)

Course : PHY1131/PHY1121 : Physics

Date of Examination : August 4, 2020 (Tuesday)

Time : 4:00 pm – 6:15 pm Reading Time : Nil

Duration : 2 hours 15 mins

Special Instructions :

Answer **ALL FOUR (4)** questions.

Material permitted : Nil

Materials provided : Nil

Examiner(s) : Manickamprasad Sambasivam & Chong Mee Teng

Chief Moderator : Mr Koh Mui Siang

DIPLOMA IN ELECTRICAL & ELECTRONIC ENGINEERING PROGRAMME (DEEI)
 DIPLOMA IN MECHANICAL ENGINEERING PROGRAMME (DMEN)
 PHY1131/PHY1121: PHYSICS
 FINAL ALTERNATIVE ASSESSMENT: APRIL 2020 SESSION

Instructions: This paper consists of **FOUR (4)** questions. Answer **ALL** questions. All questions carry equal marks.

Question 1

- (a) List the number of significant digits in the following measurements.
- (i) 5.20×10^4 kg (1 mark)
 (ii) 4.790 kg (1 mark)
- (b) The distance between two towns **P** and **Q** is 120 miles. A car travelling at an average speed of 45 miles per hour consumes 3.5 gallons of fuel. Given that 1 mile = 1.609 km and 1 gallon = 4.546 litres, calculate the fuel consumption of the car in km per litre. (3 marks)
- (c) A 50 N block is placed on a frictionless table as shown in **Figure Q1 (c)**. A 20 N mass is connected to one end of the block through a light cord that runs over a frictionless pulley. The other end of the block is tied to a wall with a light cord.

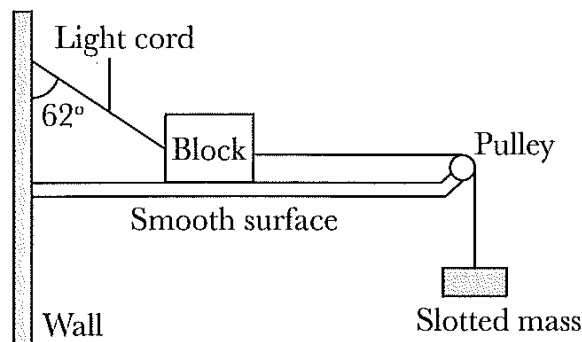

Figure Q1 (c)

- (i) Draw a free body diagram to show all the forces acting on the block. (2 marks)
 (ii) Calculate the tension, T in the light cord between the wall and the block. (3 marks)
 (iii) Calculate the normal reaction force, N that acting on the block. (2 marks)

- (d) A body falls freely from rest. Calculate
- (i) the displacement it falls in 3 s, (2 marks)
 - (ii) its speed after falling 70 m, and (3 marks)
 - (iii) the time taken to fall 300 m. (2 marks)
- (e) A bomber is flying horizontally at a speed of 245 m/s and an altitude of 305 m when it drops a bomb.
- (i) Calculate the range bomb move horizontally before it hits the ground. (4 marks)
 - (ii) Calculate its final vertical velocity just before it hits the ground. (2 marks)

Question 2

- (a) A 1.0 kg mass weighs 9.8 N on Earth's surface, and the radius of Earth is roughly 6.4×10^6 m.
- (i) Calculate the mass of Earth. (2 marks)
 - (ii) Calculate the average density of Earth. (2 marks)
- (b) A 2.70 kg block starts from rest at the top of a 30.0° incline and slides a distance of 1.90 m down the incline in 2.00 s.
- (i) Calculate the magnitude of the acceleration of the block. (1 marks)
 - (ii) Calculate the coefficient of kinetic friction between block and plane. (2 marks)
 - (iii) Compute the friction force acting on the block. (2 marks)
 - (iv) Calculate the speed of the block after it has slid 1.90 m. (1 marks)
- (c) An amount of 8.00 kcal of heat is furnished to the system while the system does 6.00 kJ of work. Calculate the internal energy of the system changes during the process. (3 marks)
- (d) On a hot day of 38°C , a concrete bridge measures $6.00 \text{ m} \times 12.0 \text{ m} \times 30.0 \text{ m}$. Calculate the allowance for change in volume necessary on a cool day as temperature drops to -15°C . (4 marks)
- (e) **Figure Q2 (e)** shows a 17.5 g bullet is fired at a muzzle velocity of 582 m/s from a gun with a mass of 8.00 kg and a barrel length of 75.0 cm.

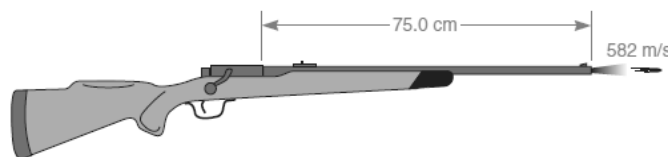

Figure Q2 (e)

- (i) Calculate the time of bullet stays in the barrel. (2 marks)
- (ii) Calculate the force of the bullet. (2 marks)
- (iii) Calculate the impulse exerted on the bullet. (2 marks)
- (iv) Calculate the bullet's momentum as it leaves the barrel. (2 marks)

Question 3

- (a) A 1.00×10^2 g aluminum block at 100.0°C is placed in 1.00×10^2 g of water at 10.0°C . The final temperature of the mixture is 25.0°C . Calculate the specific heat of the aluminum. (4 marks)
- (b) A mountain bicycle tire contains a pressure of 7.00×10^5 N/m² at a temperature of 18.0°C and contains 2.00 L of gas. Assuming tyre temperature and volume remain constant; calculate the new tyre pressure if you let out an amount of air a volume of 100 cm³ at atmospheric pressure. (7 marks)
- (c) **Figure Q3(c)** below shows stationary charges of three different positive charges. Calculate the force on the $4.0\mu\text{C}$ charge due to the other two.

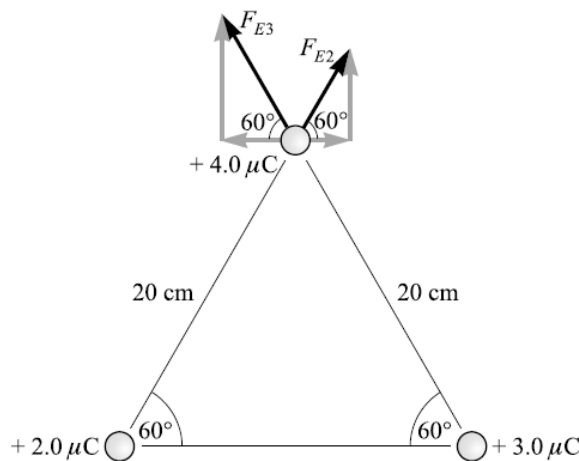

Figure Q3 (c)

(6 marks)

- (d) Two capacitors in series as in **Figure Q3 (d)** are connected to a voltage source of 1000 V. Calculate the followings:

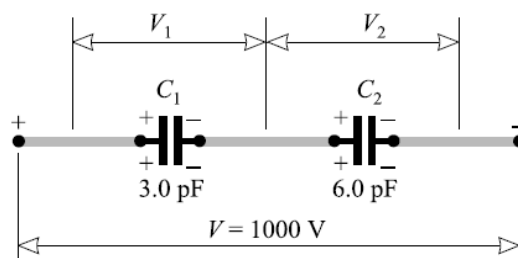

Figure Q3 (d)

- (i) The equivalent capacitance. (2 marks)
- (ii) The magnitude of the charges on the capacitors. (2 marks)
- (iii) The potential difference across the capacitors. (2 marks)
- (iv) The energy stored in the capacitors. (2 marks)

Question 4

(a) A current of 2.0 A flowing through a heater for an hour converts 1.7 MJ of electrical energy into heat energy. Calculate

- (i) the net flow of electrical charge, (2 marks)
- (ii) the potential difference across the heater, and (2 marks)
- (iii) the power rating of the heater. (2 marks)

(b) (i) Describe how to obtain *n*-type semiconductor. (2 marks)
 (ii) Describe how to obtain *p*-type semiconductor. (2 marks)
 (iii) Describe the majority charge carriers in *n*-type and *p*-type semiconductor respectively. (2 marks)

(c) **Figure Q4 (c)** shows a combinational circuit. Calculate the followings:

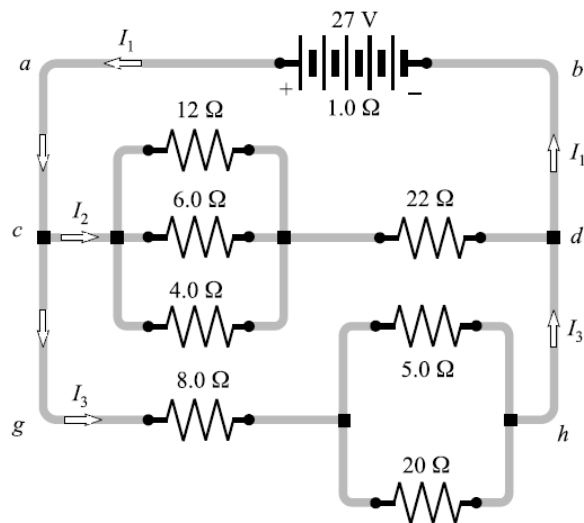

Figure Q4 (c)

- (i) The current I_1 , I_2 and I_3 . (5 marks)
- (ii) The current in 12 Ω resistor. (2 marks)

- (d) An electron travelling with a speed of 6.5×10^7 m/s enters a region of uniform magnetic field of flux density 0.316 T as shown in the **Figure Q4 (d)**. It then emerges from the field at P.

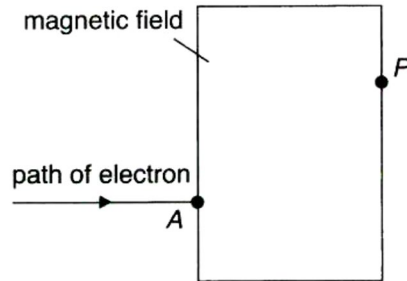

Figure Q4 (d)

- (i) Sketch the path of the electron from A to P. (2 marks)
- (ii) Sketch the path of the electron after emerging from the field. (2 marks)
- (iii) State the direction of the magnetic field. (1 mark)
- (iv) Calculate the speed of the electron after emerging from the field. (1 mark)

-THE END-

PHY1131/PHY1121/F/Apr20/formatted