



FINAL
Examination Paper

(COVER PAGE)

Session : April 2019

Programme : Diploma In Mechanical Engineering (DMEN)

Course : PHY1121 : Physics

Date of Examination : July 27, 2019 (Saturday)

Time : 2:00 pm – 4:00 pm Reading Time: Nil

Duration : 2 Hours

Special Instructions :

This paper consists of **FIVE (5)** questions. Answer any **FOUR (4)** out of **FIVE (5)** questions in the answer booklet provided. All questions carry equal marks.

Materials permitted :
Non-Programmable Scientific Calculator

Materials provided :
Physics Booklet

Examiner (s) : Manickampraslad Sambasivam and Chong Mee Teng

Moderator : Dr Chong Tet Vui

This paper consists of 7 printed pages, including the cover page.

DIPLOMA IN MECHANICAL ENGINEERING PROGRAMME (DMEN)
PHY1121: PHYSICS
FINAL EXAMINATION: APRIL 2019 SESSION

Instructions: This paper consists of **FIVE (5)** questions. Answer any **FOUR (4)** questions in the answer booklet provided. All questions carry equal marks.

Question 1

- (a) State the number of significant digits in the following measurements.
- (i) 7.250 cm (1 mark)
- (ii) 23,000 ml (1 mark)
- (b) (i) A block occupies 0.2587 ft^3 . Convert its volume in mm^3 . (2 marks)
- (ii) If you are driving at 55 mph, convert your speed in nm per second. (Given, 1 mile = 1.609344 km) (2 marks)
- (c) Show that the expression $v = v_0 + at$ is dimensionally correct, where v and v_0 represent velocities, a is acceleration, and t is a time interval. (3 marks)
- (d) **Figure Q1 (d)** shows a marble rolls down a 1.55 m ramp that is at an angle (to the positive x-axis) of 150.0° . The marble is at rest at the top of the ramp and reaches the bottom of the ramp in 1.95 seconds. Assume constant acceleration.

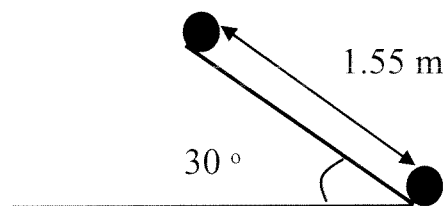

Figure Q1 (d)

- (i) Calculate the average velocity of the marble. (2 marks)
- (ii) Calculate the vertical average velocity of the marble. (2 marks)
- (iii) Calculate the horizontal average velocity of the marble. (2 marks)
- (iv) Calculate the acceleration of the marble. (2 marks)

- (e) A bullet shot vertically up into the air with a velocity of 450 m/s and it returns to the initial position as where it is shot. Neglecting air resistance, calculate:-
- (i) the time bullet in the air, and (4 marks)
 - (ii) the maximum height does the bullet go. (4 marks)

Question 2

- (a) A 200-g metal container, insulated on the outside, holds 100 g of water in thermal equilibrium at 22.0 °C. A 21.0 g ice cube, at the melting point, dropped into the water. When thermal equilibrium reached, the temperature is 15.0 °C. Assume there is no heat exchange with the surroundings. For water, the specific heat is 4190 J/kg · K and the heat of fusion is 3.34×10^5 J/kg. Determine the specific heat capacity of the metal container. (5 marks)
- (b) In physics lab, students are to launch a projectile from a point 245 m in front of a building 325 m high. The projectile is to just barely land on the top near corner of the building. Its launch velocity has unknown components. Ignore air resistance.

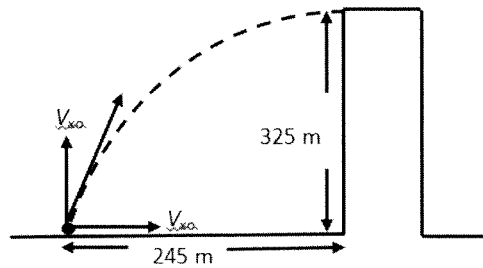

Figure Q2 (b)

- (i) Calculate the vertical component of initial velocity needed to reach the top of the building. (3 marks)
 - (ii) Calculate the horizontal component of initial velocity needed to go along with your result from part (i). (4 marks)
- (c) A 32 kg filled grocery cart is to be pushed up a frictionless ramp by a pushing force, P acting along the ramp, tilted at an angle of 6.0° above horizontal.

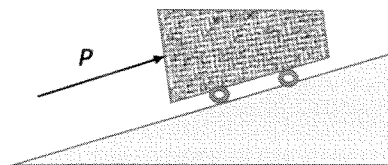

Figure Q2 (c)

- (i) Calculate the magnitude force, P needed to push the cart at constant speed. (3 marks)
- (ii) Calculate magnitude P needed to push the cart up the ramp with a constant acceleration of 2.0 m/s^2 . (3 marks)
- (d) Tarzan with mass of 85 kg is swinging back and forth while hanging on a vine with 5.0 m long. Suppose friction is negligible and he keeps swinging easily for a long time. When he passes the lowest point, his speed is 8.0 m/s .
- (i) Calculate the vine tension when he is at the lowest point. (4 marks)
- (ii) Calculate the maximum height does he swing up above the lowest point. (3 marks)

Question 3

- (a) You throw a ball with a mass of 0.40 kg against a brick wall. It is moving horizontally to the left at 30 m/s and rebounds horizontally to the right at 20 m/s after hits the wall as illustrated in **Figure Q3 (a)**.

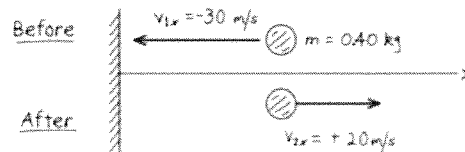

Figure Q3 (a)

- (i) Calculate the impulse of the net force on the ball during its collision with the wall. (4 marks)
- (ii) If the ball is in contact with the wall for 0.010 s , determine the average horizontal force that the wall exerts on the ball during the impact. (3 marks)
- (b) In a playground a child starts from rest at the top of a slide of height 4 m .
- (i) Calculate his speed at the bottom if the slide is frictionless. (3 marks)
- (ii) If he reaches the bottom, with a speed of 6 m/s , calculate his energy at the top and bottom of the slide in term of m , the mass of the child. Take the bottom of the slide as the reference point. (4 marks)
- (iii) Compute the percentage of his total energy at the top of the slide lost because of friction. (3 marks)

- (c) A copper bar is 80 cm at 15°C. Calculate the increase in its length when heated to 35 °C. The linear expansion coefficient for copper is $1.7 \times 10^{-5} \text{ }^\circ\text{C}^{-1}$. (2 marks)
- (d) A compressed air cylinder has a volume of 0.6 m³ and contains air at a pressure of 1.2 MPa absolute and a temperature of 37 °C. After use, the pressure is 800 kPa absolute and the temperature is 17 °C. Consider air as ideal gas and calculate
- the mass of air removed from the cylinder, and (3 marks)
 - the volume the mass of air removed would occupy at STP conditions. Take R for air as 287 J/(kg K) and atmospheric pressure as 100 kPa. (3 marks)

Question 4

- (a) Two flat parallel plates, each of length 12.0 cm, are separated by a distance of 1.5 cm, as shown in **Figure Q4 (a)**. The space between the plates is a vacuum. The potential difference between the plates is 210 V. The electric field is assumed to be uniform in the region between the plates and zero outside this region. An electron initially travels parallel to the plates along a line mid-way between the plates. The speed of the electron is $5.0 \times 10^7 \text{ m/s}$.

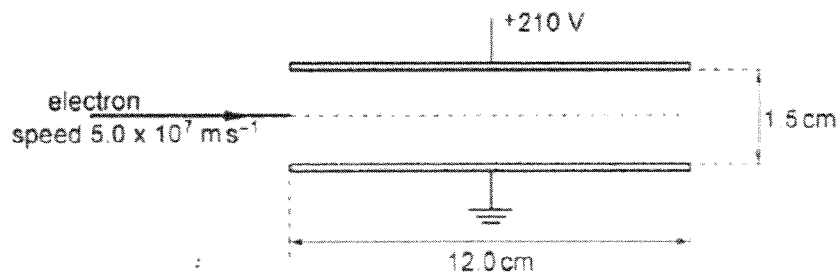

Figure Q4 (a)

- Calculate the magnitude of the electric field strength between the plates. (2 marks)
- For the electron between the plates, determine the magnitude and direction of its acceleration, (4 marks)
- Calculate the time for the electron to travel a horizontal distance equal to the length of the plates. (2 marks)
- Use your answer in part (iii) to determine whether the electron will hit one of the plates or emerge from between the plates. (3 marks)

- (b) Two positive point charges $+4.00 \mu\text{C}$ and $+2.00 \mu\text{C}$ placed at the opposite corners of a rectangle as shown in **Figure Q4 (b)**.

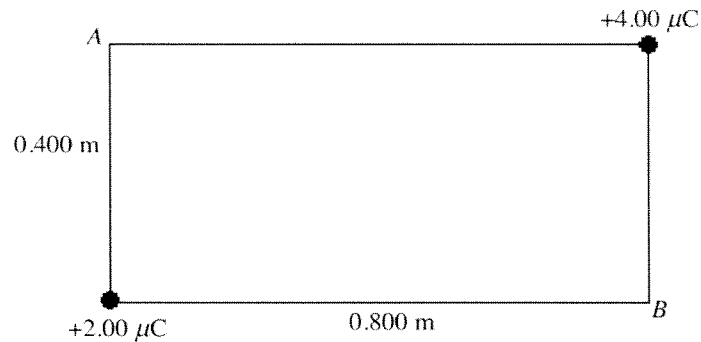

Figure Q4 (b)

- (i) Calculate the potential at point *A* (relative to infinity) due to these charges. (3 marks)
- (ii) Calculate the potential at point *B* (relative to infinity) due to these charges. (3 marks)
- (c) (i) Differentiate semiconductors, conductors and insulators based on band gap. (4 marks)
- (ii) Define a hole in a semiconductor and the hole current. (4 marks)

Question 5

- (a) An electric heater is made from a Nichrome wire which has a resistivity of $1.0 \times 10^{-6} \Omega\text{m}$ at the operating temperature. The heater is to have a power dissipation of 60 W when the potential difference across its terminals is 12 V.
- (i) Show that the resistance of the Nichrome wire is 2.4Ω . (2 marks)
- (ii) Calculate the length of Nichrome wire of diameter 0.80 mm required for the heater. (3 marks)
- (iii) A second heater, also designed to operate from a 12 V supply, is constructed using the same Nichrome wire but using half the length of that calculated in part (ii). Explain quantitatively the effect of this change in length of wire on the power of the heater. (4 marks)

(b) Calculate the followings for Figure Q5 (b) below:-

- (i) The equivalent resistance for point a and b . (4 marks)
- (ii) The currents I_1 , I_2 and I_3 . (3 marks)

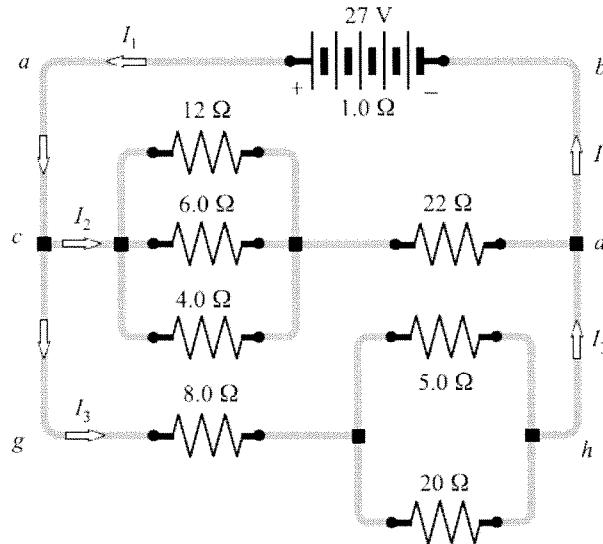

Figure Q5 (b)

(c) A proton is fired into an uniform magnetic field of strength, $B = 0.16$ T. The velocity of the proton is 8.0×10^6 ms^{-1} at right angles to the field. (It is given that mass of proton, $m_p = 1.673 \times 10^{-27}$ kg and charge of proton, $e = 1.6 \times 10^{-19}$ C)

- (i) Determine the magnitude of the force on the proton. (2 marks)
- (ii) Determine the radius of the path followed by the proton. (3 marks)
- (iii) Sketch the path followed by the proton in the magnetic field. Indicate the direction of the magnetic force on the proton in your diagram. (2 marks)
- (iv) Explain why the proton moves in a circular path. (2 marks)

-THE END-