



FINAL ALTERNATIVE ASSESSMENT
Examination Paper

(COVER PAGE)

Session : January 2022

Programme : Diploma In Information Technology (DITN)
Diploma In Computer Science (DCS)

Course : MAT1104: Discrete Mathematics

Date of Examination : March 8, 2022 (Tuesday)

Time : 12.00 pm – 2.30 pm Reading Time : Nil

Duration : 2 Hours 30 Minutes

Note: 30 minutes is added into the duration of the examination to factor in any connectivity matters and for you to scan and upload your scripts.

Special Instructions :

Answer **ALL FOUR (4)** questions.

Materials permitted : Non-Programmable Calculator

Materials provided : Nil

Examiner(s) : Mr S.M. Elizabethrani Allappan and Mr Dinash Kandasamy

Moderator : Dr Nurulanati Othman

This paper consists of 7 printed pages, including the cover page

DIPLOMA IN INFORMATION TECHNOLOGY PROGRAMME (DITN)
 DIPLOMA IN COMPUTER SCIENCE PROGRAMME (DCS)
 MAT1104: DISCRETE MATHEMATICS
 FINAL ALTERNATIVE ASSESSMENT: JANUARY 2022 SESSION

Instructions: This paper consists of **FOUR (4)** questions. Answer **ALL** questions. All questions carry equal marks.

Question 1

- (a) Rewrite each of the term of the expression

$$7312.56_8 - BA8.23_{16} - 157.25$$

into binary and simplify the expression. Present the final answer in hexadecimal.
 (6 marks)

- (b) Given P and Q are true and R and S are false, find the truth value of the following expression:

$$[\neg(P \wedge Q) \vee \neg R] \vee [(\neg P \wedge Q) \vee \neg R] \wedge S$$

(6 marks)

- (c) Given the following propositions:
 p: Shanon reads *Readers Digest*
 q: Shanon reads *Cleo*
 r: Shanon reads *Time*

Write each of the following in symbolic form:

- (i) Shanon reads *Readers Digest* or *Cleo*.
 (2 marks)
- (ii) It is not true that Shanon reads *Readers Digest* and *Time*.
 (2 marks)
- (iii) It is not true that Shanon reads *Time* or *Cleo* but not *Readers Digest*.
 (2 marks)
- (d) Calculate $2039 + 978$ using 8-4-2-1 BCD. (5 marks)

- (e) Use sign modulus format to store decimal 0.546875 in 10 bits word using.
(Show your working clearly) (2 marks)

Question 2

- (a) Determine each of the following sentences is proposition. If the sentence is a proposition, write its negation.
- (i) There exist integers x, y such that $x + y = 10$. (2 marks)
- (ii) Kuala Lumpur is in Malaysia. (2 marks)

- (b) Let $A = \{1,3,7,9,10\}$, and let R be the relation on A defined by ‘ $x^2 \leq y$ ’,
 $R = \{(x, y) \in A : x^2 \leq y\}$
- (i) Write R as a set of ordered pairs. (1 mark)
- (ii) Determine whether R is reflexive, symmetric, antisymmetric and/or transitive. (2 marks)
- (iii) Find the zero-one matrix for relation R. (1 mark)

- (c) (i) Use Karnaugh Map to simplify following expression.

$$xyzt + \overline{xyzt} + \overline{x}yzt + \overline{xy}z\overline{t} + \overline{xy}z\overline{t} + \overline{xy}z\overline{t} + \overline{xy}z\overline{t}$$

(6 marks)

- (ii) Hence, represent a logic circuit for the simplified expression. (2 marks)

- (d) Use mathematical induction to prove that the following statement is true for all positives integers k .

$$-2 - 4 - 6 \dots - 2k = -k - k^2$$

(5 marks)

(e) Answer the following questions for the tree.

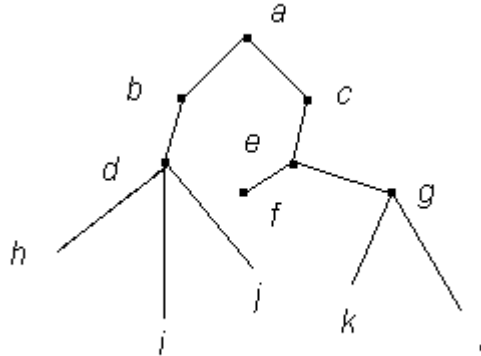

- (i) Find the ancestors of k . (1 mark)
- (ii) Find the descendants of c . (1 mark)
- (iii) Find the siblings of j . (1 mark)
- (iv) Indicate the height of this rooted tree. (1 mark)

Question 3

(a) 200 people were surveyed about their holiday destinations. The following information was obtained:

- 89 people want to go to Thailand (T)
- 73 people want to go to Singapore (S)
- 76 people want to go to Australia (A)
- 17 people want to go to both Thailand and Singapore
- 14 people want to go to both Thailand and Australia
- 20 people want to go to both Singapore and Australia
- x people want to go to all the three places

- (i) Given that 4 of them don't want to go to any of the three destinations, represent this information into a Venn diagram. (2 marks)
- (ii) Find the value of x . (2 marks)
- (iii) Find the number of people who want to visit Australia and Thailand, but not Singapore. (1 mark)

(b) The function f is defined by $f(x) = ax + b$. Given that $f(-2) = 27$ and $f(1) = 15$, find the value of x such that $f(x) = -5$.

(3 marks)

(c) If numbers are held in 8 bit register in two's complement, show how $75 - 110$ would be evaluated. Justify your answer.

(5 marks)

(d) Find the 24-bit computer representation of 25.828125, where 8 bits are used for the characteristic, and the exponent bias is $2^7 - 1$.

(5 marks)

(e) Construct a truth table for the Boolean expression given below.

$$f(x, y, z) = \bar{x}(yz + \bar{z})$$

(3 marks)

(f) Consider the following graph.

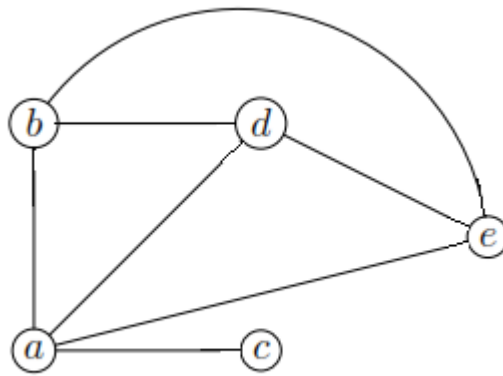

Find

(i) the number of vertices. (1 mark)

(ii) the number of edges. (1 mark)

(iii) the degree of each vertex and verify the Handshaking Theorem. (2 marks)

Question 4

(a) Convert the following accordingly. Show all working clearly.

(i) 12.5625_{10} to binary.

(2 marks)

(ii) 10011100.1011011_2 to hexadecimal.

(2 marks)

(b) Let R_1 and R_2 be the relations on $\{1, 2, 3, 4\}$ given by

$$R_1 = \{(1,1), (1,2), (3,4), (4,2)\}$$

$$R_2 = \{(1,1), (2,1), (3,1), (4,4), (2,2)\}.$$

(i) List the elements of $R_1 \cap R_2$ and $R_1 \cup R_2$.

(3 marks)

(ii) Represent digraphs for R_1 and R_2 .

(2 marks)

(c) Use Boolean algebra and De Morgan's theorems to simplify the following equation.

$$X = \overline{AB.(A+C)}$$

(5 marks)

(d) Produce a Boolean expression for the following logical network diagram.

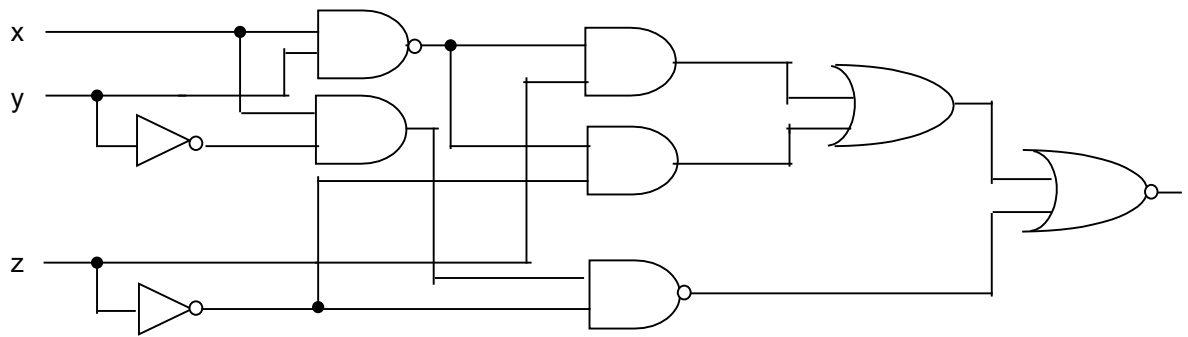

(4 marks)

(e) Consider the (8,7) parity check code, for the received word, determine whether an error will be detected.

10110101

(2 marks)

(f) Consider the (2, 8) encoding function e ,

$$e(00) = 00000000$$

$$e(01) = 10110100$$

$$e(10) = 01100010$$

$$e(11) = 11010111$$

Find the

(i) minimum distance of the encoding function. (4 marks)

(ii) number of errors detected by the encoding function detect. (1 mark)

~THE END~

MAT1104 (F)/ Jan 2022 Session/ formatted