

INTI

INTERNATIONAL COLLEGE PENANG (507232-U)
LAUREATE INTERNATIONAL UNIVERSITIES

FINAL
Examination Paper
(COVER PAGE)

Session : JANUARY 2014

Programme : DIPLOMA IN ELECTRICAL & ELECTRONIC ENGINEERING

Course : PHY 1121: PHYSICS

Date of Examination : 12 March 2014

Time : 2.00PM – 4.00PM Reading Time : Nil

Duration : 2 Hours

Special Instructions :

This paper consists of FIVE (5) questions. Answer any FOUR (4) questions in the answer booklet provided. All questions carry equal marks.

Materials permitted :
Non-Programmable Calculator

Materials provided :
Physics Formula Booklet

Examiner(s) : Chong Mee Teng

Moderator : Yeap Ah Choo

This paper consists of 6 printed pages, including the cover page.

INTI INTERNATIONAL COLLEGE PENANG
DIPLOMA IN ELECTRICAL AND ELECTRONIC ENGINEERING PROGRAMME

PHY 1121: PHYSICS
FINAL EXAMINATION: JANUARY 2014 SESSION

Instructions: This paper consists of **FIVE (5)** questions. Answer any **FOUR** questions in the answer booklet provided. All questions carry equal marks.

Question 1

- (a) A solid piece of lead has a mass of 23.94 g and a volume of 2.10 cm^3 . From these data, calculate the density of lead in SI units (kgm^{-3}). (4 marks)
- (b) A sphere of radius r moves at a speed v in a viscous fluid. The sphere is acted on by a viscous force F which is given by $F = krv$. Determine the dimensions of k . (4 marks)
- (c) A plane starts from rest and accelerates along the ground before takeoff. It moves 600 m in 12 s. Find:
- (i) the acceleration of the plane and its speed at the end of 12 s. (4 marks)
 - (ii) the distance moved during the twelfth second. (4 marks)
- (d) In **Figure (1)**, $m_1 = 3.0 \text{ kg}$, $m_2 = 8.0 \text{ kg}$ and $\theta = 20.0^\circ$. The inclined plane is frictionless.

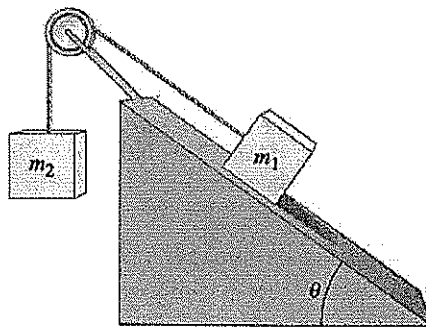

Figure (1)

- (i) Draw a free body diagram for each block. (3 marks)
- (ii) Find the acceleration of the blocks. (4 marks)
- (iii) Find the tension in the cord. (2 marks)

Question 2

- (a) A baseball, thrown upward, leaves the player's hand at a height of 1.50 m above a playing field. The ball has an initial speed of 16.0 ms^{-1} at an angle 40° to the horizontal.
- (i) What is its maximum height of the ball from the ground? (3 marks)
 - (ii) How long does it take to strike the field? (3 marks)
 - (iii) What is the vertical component of its velocity just before it strikes the field? (2 marks)
- (b) **Figure (2)** shows a bead sliding on a wire. If friction forces are negligible and the bead has a speed of 2.0 m/s at *A*, find the speed at points *B* and *C*: (6 marks)

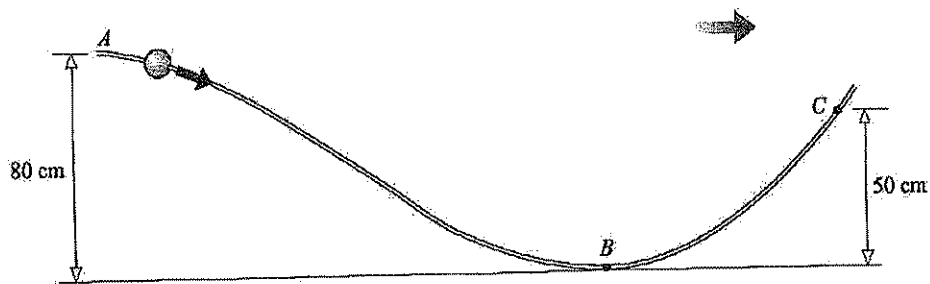

Figure (2)

- (c) A 50.0 kg satellite moves in a circular orbit 750.0 km above Earth's surface with a period of 98.0 min . (Given mass of Earth, $M_E = 5.98 \times 10^{24} \text{ kg}$, radius of Earth, $R_E = 6.37 \times 10^6 \text{ m}$). Find:
- (i) the speed of the satellite, (2 marks)
 - (ii) the kinetic energy of the satellite, (2 marks)
 - (iii) the centripetal acceleration of the satellite. (2 marks)
- (d) **Figure (3)** shows three small charges *A*, *B* and *C* in a line. Charges *A* and *C* are positive while charge *B* is negative. Calculate the resultant force on charge *C*. (Given $k = 8.988 \times 10^9 \text{ N.m}^2\text{C}^{-2}$) (5 marks)

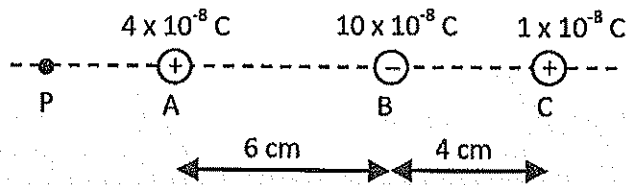

Figure (3)

Question 3

- (a) A 16.0 g object is moving to the right at 0.3 ms^{-1} while a 4.0 g object is moving in the opposite direction at 0.5 ms^{-1} . They collide head on and stick together.
- State the type of collision. (1 mark)
 - Find the magnitude and direction of their velocity after the collision. (4 marks)
 - Find their kinetic energy after the collision. (3 marks)
- (b) A physics student wants to cool 0.25 kg of Diet Omni-Cola (mostly water), initially at 25°C , by adding ice initially at -20°C . The temperature finally becomes 0°C with all the ice melted. (Given the specific heat capacity of water, $c_w = 4190 \text{ Jkg}^{-1}\text{K}^{-1}$, specific heat capacity of ice, $c_i = 2.1 \times 10^3 \text{ Jkg}^{-1}\text{K}^{-1}$ and the latent heat of fusion of water, $L_f = 3.34 \times 10^5 \text{ Jkg}^{-1}$).
- Calculate the heat loss of the Omni-Cola. (3 marks)
 - What is the mass of ice need to be added? (neglect the heat capacity of the container). (6 marks)
- (c) **Figure (4)** shows a region of uniform electric field between two parallel plates separated by a distance of 0.040 m. Protons are released at high speeds from plate *A* and move directly towards plate *B*. (Given the charge of proton, $p = 1.60 \times 10^{-19} \text{ C}$). Calculate:

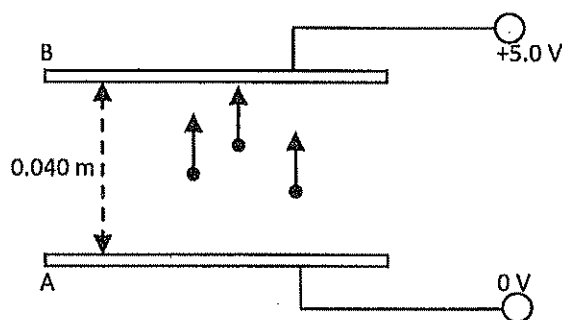

Figure (4)

- the electric field strength, assuming it is in a vacuum. (2 marks)
- the change in electric potential energy of a proton as it moves from *A* to *B*. (3 marks)
- the minimum velocity of the protons so as to reach *B*. (3 marks)

Question 4

- (a) A quantity of ideal gas at 10.0°C and 100 kPa occupies a volume of 2.50 m^3 . (Given the universal gas constant, $R = 8.31\text{ Jmol}^{-1}\text{K}^{-1}$)
- Convert the 10.0°C to Kelvin scale. (2 marks)
 - How many moles of the gas are present? (2 marks)
 - If the pressure is now raised to 300 kPa and the temperature is raised to 30.0°C , how much volume does the gas occupy? Assume no leaks. (3 marks)

- (b) An electron, moving with a speed $v = 2.00 \times 10^6\text{ ms}^{-1}$, enters a uniform magnetic field of strength $B = 4.50\text{ T}$ at an angle of $\theta = 40^\circ$ to the field, as shown in Figure (5).

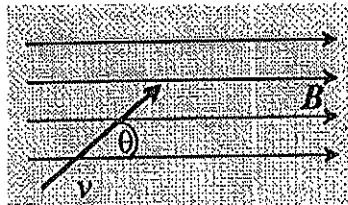

Figure (5)

- Find the magnetic force acting on the electron. (3 marks)
 - Find the force on an electron moving from left to right as it enters this field. (2 marks)
 - Find the force on an electron moving down the page as it enters this field. (3 marks)
- (c) Compute the magnetic field strength in air at a point 5.0 cm from a long straight wire carrying a current of 15.0 A . (Given the permeability of free space, $\mu_0 = 4\pi \times 10^{-7}\text{ T.m/A}$) (4 marks)
- (d) A laser beam is aimed at a sheet of glass 1.0 cm thick, at an angle 30° with the surface of the glass. The refractive index of glass is 1.5 .
- What is the laser beam's angle of refraction in the glass? (3 marks)
 - What is its direction in the air on the other side of the glass? (3 marks)

Question 5

- (a) A cylinder of diameter 1.00000 cm at 30.0°C is to be slid into a hole in a steel plate. The hole has a diameter of 0.99970 cm at 30.0°C. To what temperature must the plate be heated? (Given $\alpha_{steel} = 1.1 \times 10^{-5} \text{ } ^\circ\text{C}^{-1}$) (5 marks)
- (b) A parallel plate capacitor consisting of two plates, each with area of 200.0 cm², is charged with 9.6 nC and has a 120.0 V potential difference between its terminals. (Given the permittivity of free space, $\epsilon_0 = 8.85 \times 10^{-12} \text{ C}^2\text{N}^{-1}\text{m}^{-2}$). Compute:
- the capacitance, (2 marks)
 - the plate separation, and (3 marks)
 - the energy stored in the capacitor. (3 marks)
- (c) From **Figure (6)**, find:

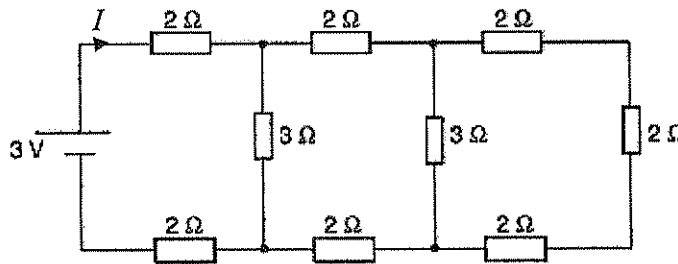

Figure (6)

- the total resistance in the circuit. (4 marks)
 - the current I . (2 marks)
- (d) A convex lens forms an image of a real object placed 10 cm in front of the lens. The image is magnified 3 times.
- Calculate the distance of the image from the lens. (3 marks)
 - What is the focal length of the lens? (3 marks)

—THE END—
Phy1121/F/jan14/cmt