

**INTI**

INTERNATIONAL COLLEGE PENANG (507232-U)  
LAUREATE INTERNATIONAL UNIVERSITIES

FINAL  
Examination Paper

(COVER PAGE)

Session : January 2013

Programme : DIPLOMA IN ELECTRICAL AND ELECTRONIC ENGINEERING

Course : EEE 1101: BASIC ELECTRICAL TECHNOLOGY

Date of Examination : 4 March 2013

Time : 11a.m. – 1p.m. Reading Time : Nil

Duration : 2 Hours

Special Instructions :

This paper consists of **SIX (6)** questions. Answer any **FOUR (4)** questions in the answer booklet provided. All questions carry equal marks.

Materials permitted :

Non-Programmable Scientific Calculator

Materials provided :

Examiner(s) : **Shalyn Lim Sheue Hui**

Moderator : **Steven Khoo**

*This paper consists of 8 printed pages, including the cover page.*

## INTI INTERNATIONAL COLLEGE PENANG

## DIPLOMA IN ELECTRONIC AND ELECTRICAL ENGINEERING PROGRAMME (DEEI)

## DIPLOMA IN ENGINEERING PROGRAMME

EEE 1101 : BASIC ELECTRICAL TECHNOLOGY  
FINAL EXAMINATION : JANUARY 2013 SESSION

Instructions: This paper consists of SIX (6) questions. Answer any FOUR (4) questions in the answer booklet provided. All questions carry equal marks.

## Question 1

- (a) Define electrical power. (2 marks)
- (b) An electric heater develops a power of 1kW where run on 230 Vdc supply. If the resistance wire of the heater has diameter of 0.5mm and resistivity of  $60 \times 10^{-8} \Omega\text{m}$ , find the length of the wire. (4 marks)
- (c) With reference to Figure Q1(c),
- (i) Find the currents  $I_5$ ,  $I_5$ , and voltage  $V_7$ . (8 marks)
- (ii) Calculate the power dissipated by resistors  $R_1$ ,  $R_6$  and also the total supplied power,  $P_T$ . (6 marks)

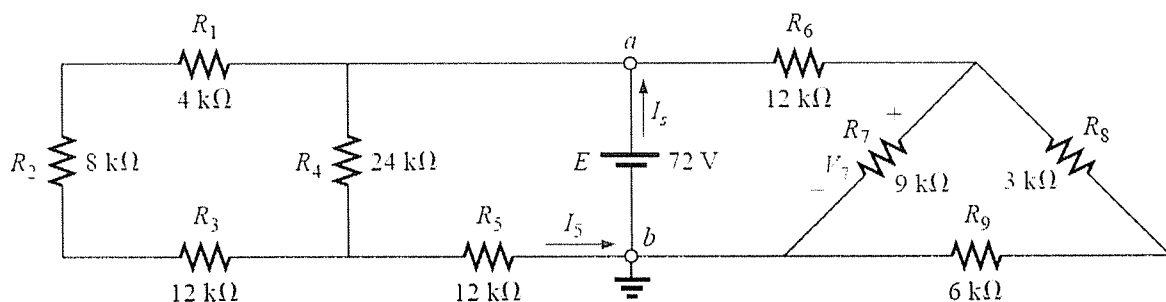

Figure Q1(c)

- (d) With reference to Figure Q1(d), find the resistance,  $R$ . Next, calculate the total supplied current from 240V.

(5 marks)

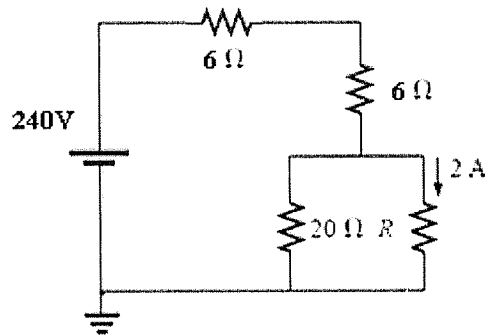

Figure Q1(d)

Question 2

- (a) Determine the current through  $2\Omega$  resistor of Figure Q2(a) by applying Norton's theorem.

(7 marks)

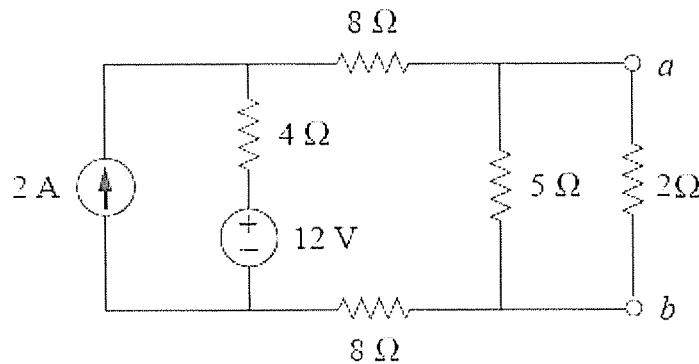

Figure Q2(a)

- (b) For the circuit shown in Figure Q2(b), using nodal analysis to determine  $V_1$ ,  $V_2$  and  $I$ .

(7 marks)

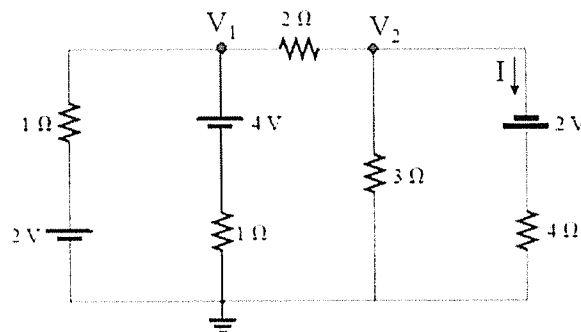

Figure Q2(b)

- (c) Calculate the value of resistor,  $R_L$  for maximum power transfer in Figure Q2(c). Next find the maximum power through  $R_L$ .

(7 marks)

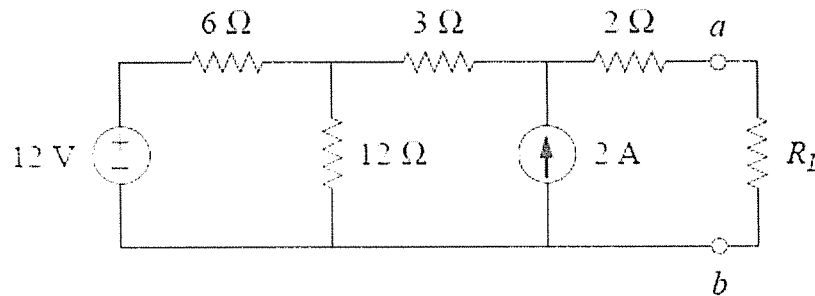

Figure Q2(c)

- (d) Refer to the circuit in Figure Q2(d), calculate total resistance using star –delta transformation.

(4 marks)

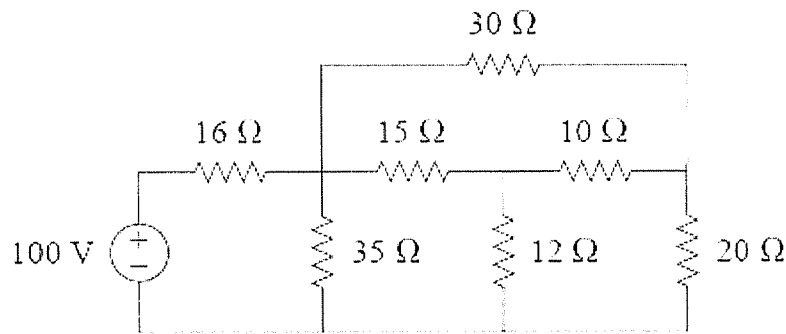

Figure Q2(d)

### Question 3

- (a) Define Magneto motive force (MMF) and provide the equation.

(3 marks)

- (b) A toroid of mean radius 40 mm with effective cross sectional area of  $3 \text{ cm}^2$  and relative permeability 150 is wound with 900 turns coil that carries a current of 1.5 A. Calculate

- (i) the MMF

(1 marks)

- (ii) The magnetic field strength

(2 marks)

- (iii) the flux density

(3 marks)

(c) A magnetic circuit has three parts connected in series. They are :

- (1)  $l_a = 65\text{mm}$  ,  $A_a = 40\text{ mm}^2$  ,  $\mu_r = 1200$
- (2)  $l_b = 50\text{mm}$  ,  $A_b = 75\text{ mm}^2$  ,  $\mu_r = 1200$
- (3)  $l_c = 1\text{ mm}$  ,  $A_b = 120\text{ mm}^2$  ,  $\mu_r = 1$

A coil of 3800 turns is wound with the magnetic circuit and the flux density in part (3) is 0.22T. Neglecting any magnetic leakage, calculate the coil current to produce such a flux density.

(10 marks)

(d) Two coils are placed side by side with their combined inductance when connected in series is 1 H or 0.2 H depending on the relative direction of the currents in the coils. If the self-inductance of one of the coils when isolated is 0.2 H, find

(i) the inductance of the other coil

(3 marks)

(ii) the mutual inductance

(2 marks)

(iii) the coupling coefficient

(1 marks)

#### Question 4

(a) A 600 turn coil is wound on to a non-magnetic core of effective length 45 mm and cross sectional area is  $4\text{ cm}^2$ .

(i) Calculate the inductance

(2 marks)

(ii) Calculate the inductance if the number of turns is increased to 900.

(3 marks)

(iii) If the core of the part (ii) now replaced by an iron core having a relative permeability of 75 and the same dimensions as the original. Calculate the inductance for this case.

(2 marks)

- (b) Refer to network in Figure Q4(b), calculate the total inductance across the terminal of ab.  
(3 marks)

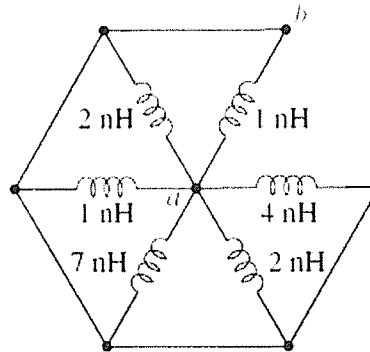

in Figure Q4(b)

- (c) The switch in the circuit of Figure Q4(c) has been closed for a long time, calculate  $i(t)$  when the switch is open for 5 s.  
(7 marks)

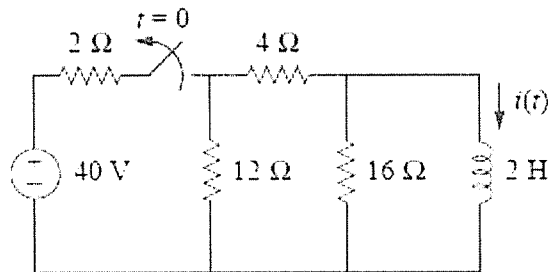

Figure Q4(c)

- (d) The switch in the circuit shown in Figure Q4(d) closes at  $t = 0$ . Find  $v_c$  at  $t = 0.2$  s and sketch the equivalent circuit.  
(8 marks)

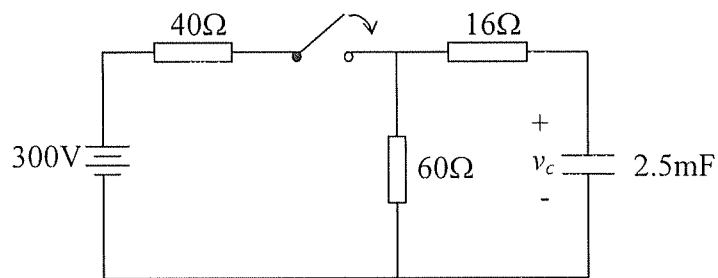

Figure Q4(d)

## Question 5

- (a) Explain the differences between the terms average values and r.m.s values. (2 marks)
- (b) The current in an a.c. circuit at any time  $t$  seconds is given by  $i=120 \sin(100\pi t + 0.36)$  amperes. Find
- the period. (2 marks)
  - the value of the currents when  $t = 0$  ms and  $t = 8$  ms. (3 marks)
  - the time when the current is reaches a first maximum. (3 marks)
- (c) The following expressions represent the instantaneous values of voltage in three coils connected in series.
- $$e_1 = 40 \sin \omega t \text{ V}$$
- $$e_2 = 30 \cos (\omega t + 60^\circ) \text{ V}$$
- $$e_3 = 70 \sin (\omega t - 30^\circ) \text{ V}$$
- Find the time domain expression for the resultant voltage. (5 marks)
- (d) A coil of negligible resistance and inductance of 100mH is connected in series with a capacitance of 2  $\mu\text{F}$  and a resistance of 10 $\Omega$  across a 50V, variable frequency supply. Determine
- the resonant frequency. (2 marks)
  - the current at resonance. Justify the resonance condition happens with quantitative calculation. (6 marks)
  - the Q-factor of the circuit. (2 marks)

Question 6

(a) A coil of inductance  $159.2\text{mH}$  and resistance  $20\ \Omega$  is connected in series with a  $60\ \Omega$  resistor to a  $240\ \angle 0^\circ\text{V}_{\text{rms}}$ ,  $50\ \text{Hz}$  supply. Determine [express the answer in polar form]

(i) the impedance of the circuit . (3 marks)

(ii) the current in the circuit . (2 marks)

(iii) the potential difference across the coil. (3 marks)

(b) Referring to Figure Q6(b) below, determine [express the answer in polar form]

(i) the total impedance. (7 marks)

(ii) the total current,  $I$ . (2 marks)

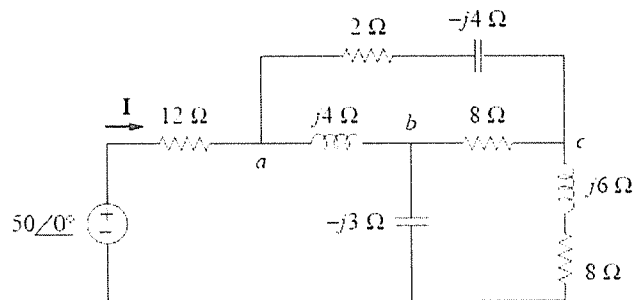

Figure Q6(b)

(c) A load  $Z$  draws  $12\ \text{kVA}$  at a power factor of  $0.856$  lagging from a  $120\text{-V}$  rms sinusoidal source. Calculate

(i) the average and reactive powers delivered to the load. (2 marks)

(ii) the peak current. (4 marks)

(ii) the load impedance. (2 marks)

--THE END--