



**FINAL  
ALTERNATIVE ASSESSMENT**

(COVER PAGE)

Session : April 2021

Programme : Diploma in Electrical & Electronic Engineering (DEEI)

Course : EEE2114: Introduction to Embedded System

Date of Examination : 26 July 2021 (Monday)

Time : 2.00pm – 5.00pm Reading Time : Nil

Duration : 3 Hours

**Special Instructions :**

This paper consists of **FOUR (4)** questions. Answer **ALL** the questions. All questions carry equal marks.

Material permitted : Nil

Materials provided : Nil

Examiner(s) : Johnny Wong Kee Hui

Chief Moderator : Dr. Su Hsiao Wei

*This paper consists of 8 printed pages, including the cover page*

## INTI INTERNATIONAL COLLEGE PENANG

DIPLOMA IN ELECTRICAL & ELECTRONICS ENGINEERING PROGRAMME (DEEI)  
 EEE2114: INTRODUCTION TO EMBEDDED SYSTEMS  
 FINAL ALTERNATIVE ASSESSMENT: APRIL 2021 SESSION

**Instructions:** This paper consists of **FOUR (4)** questions. Answer all **FOUR (4)** questions. All questions carry equal marks.

**Question 1**

- a) Provide the differences between PIC16F628A microcontroller and PIC16F877A microcontroller by completing Table 1(a) as shown below.

Table 1(a)

Description	PIC16F628A	PIC16F877A
Ports (Number of Bits) E.g. Port A(2)		
Number of Analog Pins		
Total I/O Pins		
Data Memory (Bytes)		
Program Flash (Words)		
Data EEPROM (Bytes)		
ADC-bit (Channel)		
CCP (PWM)		
SSP		
Internal Oscillator (Hz)		

(10 marks)

- b) Figure 1(b) shows output connection of PIC16F628A microcontroller driving 4 LEDs in parallel configuration.
- i) Determine if the circuit is going to work when Port B, RB1 is outputting a High or Logic 1. (3 marks)
  - ii) Referring to the Electrical Characteristics of the microcontroller as shown in Table 1(b), justify your explanation with calculation whether Figure 1(b) configuration is going to work. (3 marks)
  - iii) If it is not working, then present a workable solution. (4marks)

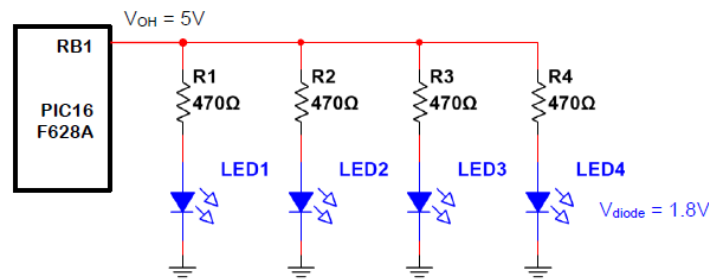

Figure 1(b)

Table 1(b) Electrical Characteristics

<b>Absolute Maximum Ratings †</b>	
Ambient temperature under bias.....	-55 to +125°C
Storage temperature .....	-65°C to +150°C
Voltage on any pin with respect to V <sub>SS</sub> (except V <sub>DD</sub> , MCLR, and RA4) .....	-0.3V to (V <sub>DD</sub> + 0.3V)
Voltage on V <sub>DD</sub> with respect to V <sub>SS</sub> .....	-0.3 to +7.5V
Voltage on MCLR with respect to V <sub>SS</sub> ( <b>Note 2</b> ) .....	0 to +14V
Voltage on RA4 with respect to V <sub>SS</sub> .....	0 to +8.5V
Total power dissipation ( <b>Note 1</b> ) .....	1.0W
Maximum current out of V <sub>SS</sub> pin .....	300 mA
Maximum current into V <sub>DD</sub> pin .....	250 mA
Input clamp current, I <sub>IK</sub> (V <sub>I</sub> < 0 or V <sub>I</sub> > V <sub>DD</sub> ).....	± 20 mA
Output clamp current, I <sub>OK</sub> (V <sub>O</sub> < 0 or V <sub>O</sub> > V <sub>DD</sub> ).....	± 20 mA
Maximum output current sunk by any I/O pin.....	25 mA
Maximum output current sourced by any I/O pin .....	25 mA
Maximum current sunk by PORTA, PORTB and PORTE (combined) ( <b>Note 3</b> ).....	200 mA
Maximum current sourced by PORTA, PORTB and PORTE (combined) ( <b>Note 3</b> ).....	200 mA
Maximum current sunk by PORTC and PORTD (combined) ( <b>Note 3</b> ) .....	200 mA
Maximum current sourced by PORTC and PORTD (combined) ( <b>Note 3</b> ) .....	200 mA

**Note 1:** Power dissipation is calculated as follows:  $P_{dis} = V_{DD} \times \{I_{DD} - \sum I_{OH}\} + \sum \{(V_{DD} - V_{OH}) \times I_{OH}\} + \sum (V_{OI} \times I_{OL})$

**Note 2:** Voltage spikes below V<sub>SS</sub> at the MCLR pin, inducing currents greater than 80 mA, may cause latch-up. Thus, a series resistor of 50-100Ω should be used when applying a “low” level to the MCLR pin rather than pulling this pin directly to V<sub>SS</sub>.

**Note 3:** PORTD and PORTE are not implemented on PIC16F873A/876A devices.

† NOTICE: Stresses above those listed under “Absolute Maximum Ratings” may cause permanent damage to the device. This is a stress rating only and functional operation of the device at those or any other conditions above those indicated in the operation listings of this specification is not implied. Exposure to maximum rating conditions for extended periods may affect device reliability.

c) “An embedded system can be a very simple piece of electronic circuitry that performs a specific function within a larger system”. Describe how a computer mouse can be an example of embedded systems applications.

(5 marks)

**Question 2**

a) Referring to Figure 2(a),

i) Describe the serial communications used in PIC microcontroller.

(6 marks)

ii) Provide TWO (2) comparisons between SPI mode and I2C mode.

(2 marks)

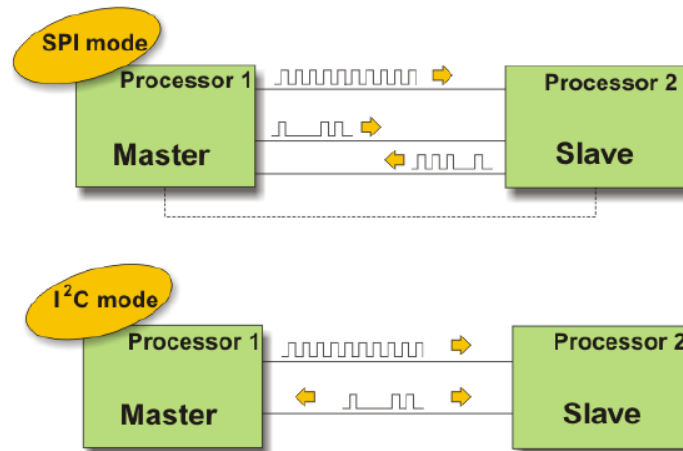

Figure 2(a)

b) The TXTSA Register and RCSTA Register of a PIC16F877A microcontroller is set as shown in Table 2(b1) and Table 2(b2) respectively. Table 2(b3) indicates the setting required for configuring the 9600 baud rate for 4 MHz oscillator at high speed operating in asynchronous mode using 8-bit data. Assume that there is no error and awaiting for the data being to be transmitted. Table 2(b4) shows the Baud Rate Formula for this specific microcontroller.

Table 2(b1) TXTSA register

TXTSA Register	bit 7	bit 6	bit 5	bit 4	bit 3	bit 2	bit 1	bit 0
	0	0	1	0	0	1	0	0

Table 2(b2) RCSTA register

RCSTA Register	bit 7	bit 6	bit 5	bit 4	bit 3	bit 2	bit 1	bit 0
	1	0	0	0	0	0	0	0

Table 2(b3) SPBRG register

SPBRG Register	bit 7	bit 6	bit 5	bit 4	bit 3	bit 2	bit 1	bit 0
	?	?	?	?	?	?	?	?

Table 2(b4) Baud Rate Formula

SYNC	BRGH = 0 (Low Speed)	BRGH = 1 (High Speed)
0	(Asynchronous) Baud Rate = $F_{osc}/(64(X + 1))$	Baud Rate = $F_{osc}/(16(X + 1))$
1	(Synchronous) Baud Rate = $F_{osc}/(4(X + 1))$	N/A

Legend: X = value in SPBRG (0 to 255)

- i) Describe in details the setting used for TXSTA register. (3 marks)
- ii) Describe in details the setting used for RCSTA register. (3 marks)
- iii) Determine the setting used for SPBRG register. Show the calculation working clearly. (4 marks)

c) Figure 2(c) shows the PIC16F877A to PIC16F877A communication via Universal Synchronous Receiver Transmitter (UART). Describe the UART communication between these two PIC microcontrollers. State on the typical baud rate used for this communication. Assume the communication protocol used is 8N1. (7 marks)

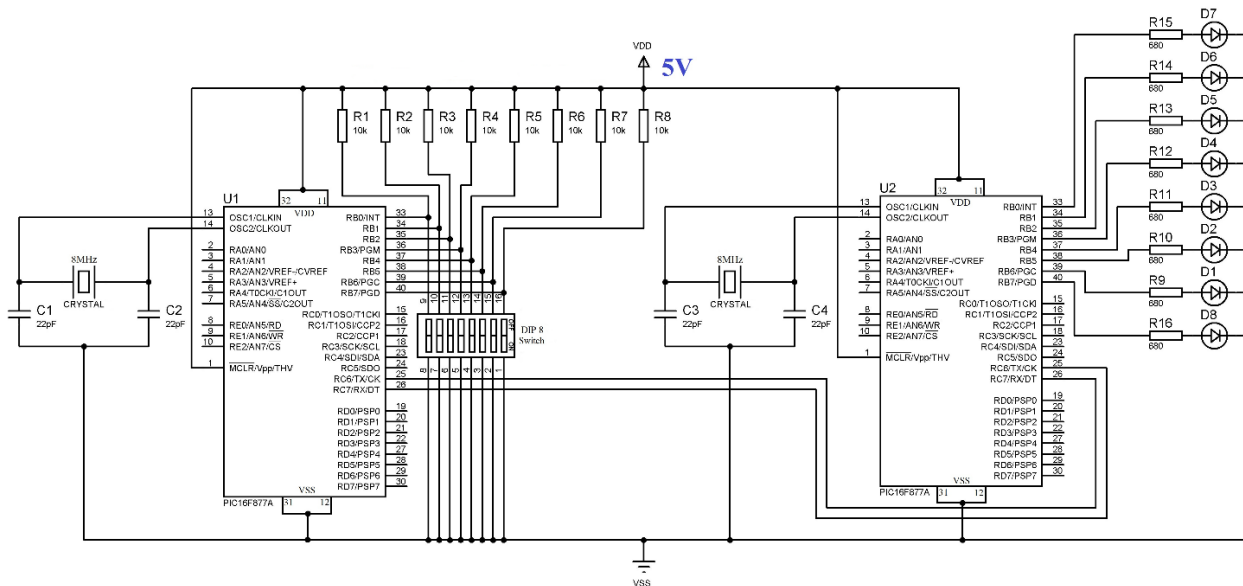

Figure 2(c)

**Question 3**

- a) A Timer 2 is used to generate a delay of 60µs, as shown in block diagram in Figure 3(a).
  - i) Determine the value of the PR2 if the TMR2 is 0, the prescaler and postscaler of 1:1 are selected. Assume that the crystal clock is running at the frequency of 16MHz. Ignore the overhead due to instructions in the calculation. (5 marks)
  - ii) Explain how the microcontroller knows the delay of 60µs has reached. (3 marks)

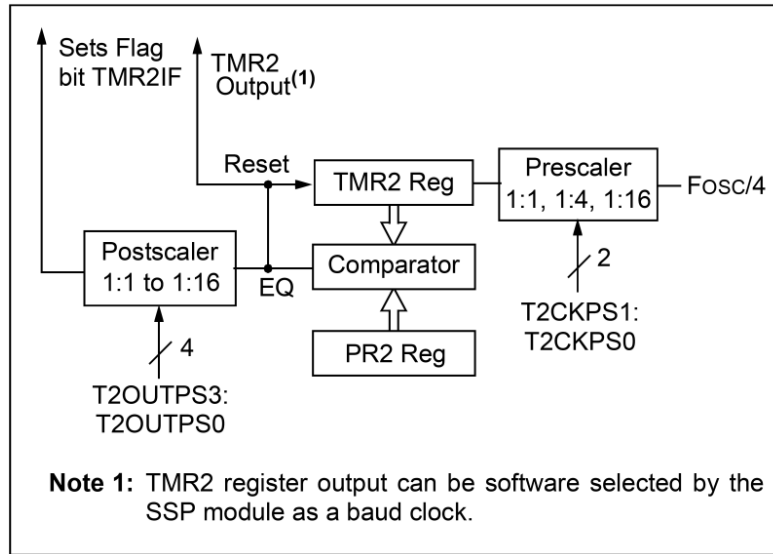

Figure 3(a)

b) Referring to figure 3(b),

i) Explain THREE (3) types of memories available in the Peripheral Interface Controller (PIC) microcontroller and how each of them are being used by the programmer. The description should include the size and the range of each memory explained. Also, explain the amount of memory left in Data memory and Program memory.

(8 marks)

ii) State the possible type of microcontroller used.

(1 marks)

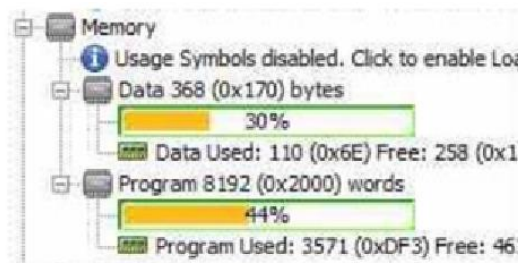

Figure 3(b)

c) The PIC16F877A analogue to digital converter (ADC) is being configured. In this design, an internal voltage reference is selected, input channel 3 is selected, and the ADC is switched on but not running. Assume that channel 0, channel 1, channel 2 and channel 4 are configured as analogue input only. Also, assume that the conversion clock used is  $F_{osc}/4$  with left justification on the result.

- i) Determine the setting for the ADCON0 register. (2 marks)
- ii) Determine the setting for the ADCON1 register. (2 marks)
- iii) Give one advantage of using an internal voltage reference or an external voltage reference. (4 marks)

**Question 4**

a) The INTCON Register of a PIC16F628A microcontroller is set as shown in Table 4(a1).

Table 4(a1)

INTCON Register	bit 7	bit 6	bit 5	bit 4	bit 3	bit 2	bit 1	bit 0
	1	0	1	0	1	0	0	0

- i) Determine which interrupts are enabled. (3 marks)
- ii) An interrupt occurs and the INTCON register is found to have changed to the setting shown in Table 4(a-2). Which interrupt source has called? (2 marks)

Table 4(a2)

INTCON Register	bit 7	bit 6	bit 5	bit 4	bit 3	bit 2	bit 1	bit 0
	1	0	1	0	1	0	0	1

b) Name the architecture for Figure 4(b1) and Figure 4(b2). Compare the operation of Figure 4(b1) architecture with Figure 4(b2) architecture. (4 marks)

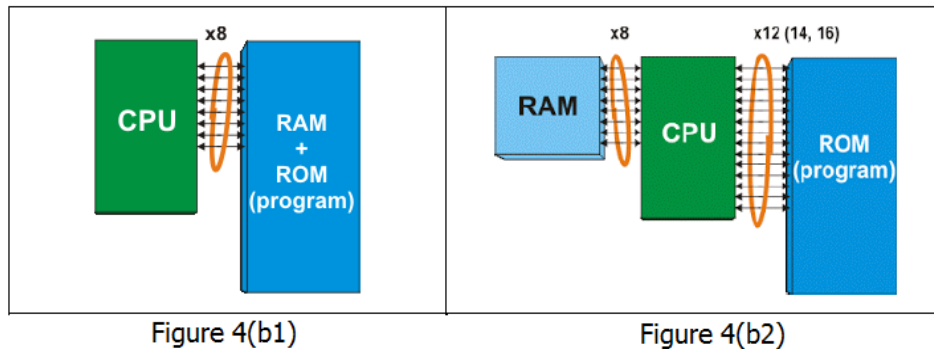

c) Name and describe the function of the following label as shown in figure 4(c).

- i) Label (A) (3 marks)
- ii) Label (B) (3 marks)
- iii) Label (C) (3 marks)
- iv) Label (D) (3 marks)
- v) Label (E) (3 marks)

State the possible type of microcontroller for Figure 4(c) internal architecture. (1 mark)

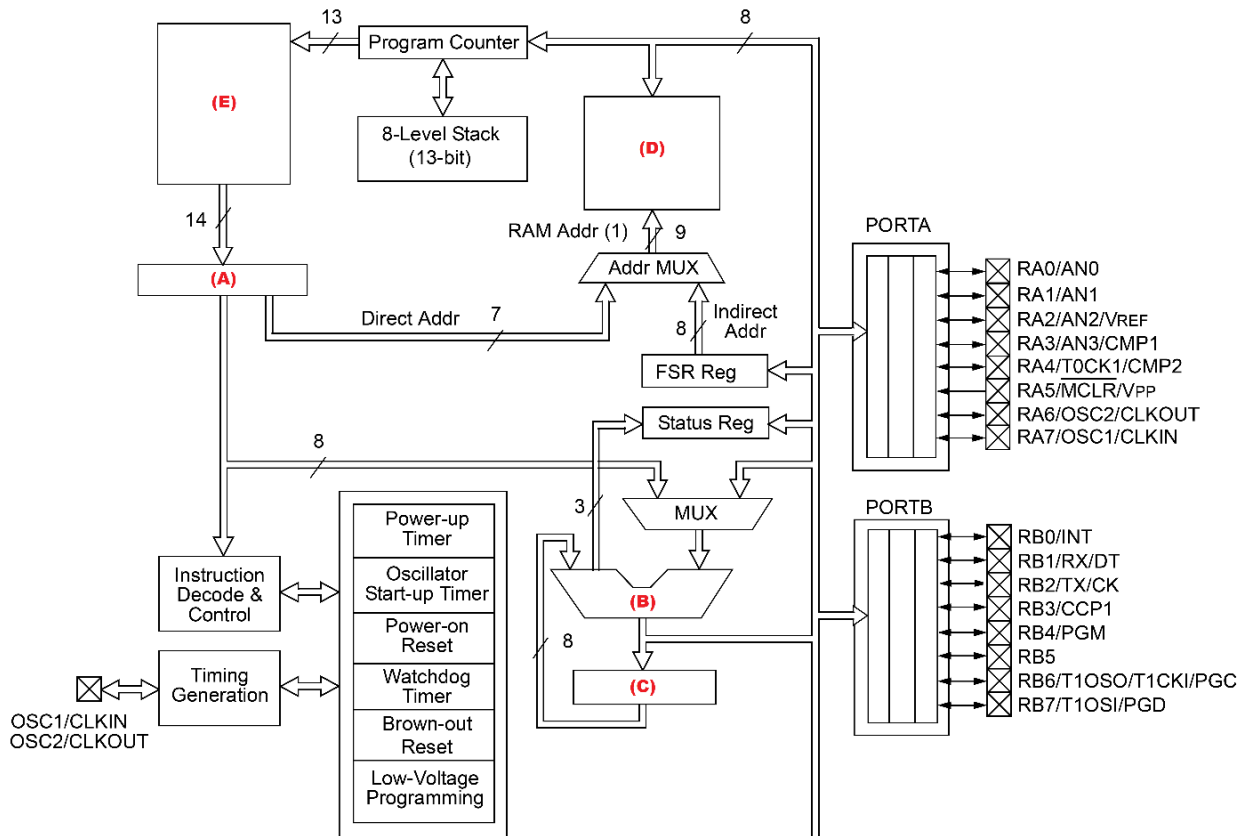

Figure 4(c)

~THE END~