



INTI
International College Penang

FINAL
Examination Paper

(COVER PAGE)

Session : August 2019

Programme : Diploma in Electrical and Electronic Engineering (DEEI)

Course : EEE2113: Electric Power Systems and Machines

Date of Examination : 9 December 2019 (Monday)

Time : 2:00pm – 4:00pm Reading Time : Nil

Duration : 2 Hours

Special Instructions :

This paper consists of **SIX (6)** questions. Answer any **FOUR (4)** questions in the answer booklet provided. All questions carry equal marks.

IMPORTANT NOTE : THIS PAPER SHOULD NOT BE TAKEN OUT OF THE EXAMINATION HALL

Materials permitted :
Non-Programmable Scientific Calculator

Materials provided :
Nil

Examiner(s) : Mr. Alan Wong Kam Mun

Moderator : Dr. Ooi Beng Lee

This paper consists of 7 printed pages, including the cover page.

INTI INTERNATIONAL COLLEGE PENANG

DIPLOMA IN ELECTRICAL AND ELECTRONIC ENGINEERING PROGRAMME (DEEI)
 EEE 2113: ELECTRIC POWER SYSTEMS AND MACHINES
 FINAL EXAMINATION: AUGUST 2019 SESSION

Instructions: This paper consists of **SIX (6)** questions. Answer any **FOUR (4)** questions in the answer booklet provided. All questions carry equal marks.

Question 1

(a) A generating station has the following daily loads:

Time(24hrs)	0 – 6	6 – 8	8 – 12	12 - 14	14 - 18	18 - 20	20 - 24
Load(kW)	4500	3500	7500	2000	8000	2500	5000

Given the capacity of the plant is 12 MW.

- (i) Sketch the load curve and load duration curve. (6 marks)
- (ii) Determine the load factor. (7 marks)
- (iii) Determine the plant capacity factor. (3 marks)

(b) A generator station supplies the following loads to various consumers:

- Industry consumer = 1500kW
- Commercial Establishment = 750kW
- Domestic Power = 100kW
- Domestic Light = 450kW

If the maximum demand on the station is 2500kW and the number of kWh generated per year is 45×10^5 , determine:

- (i) The diversity factor. (4 marks)
- (ii) Annual load factor. (5 marks)

Question 2

(a) Draw an impedance diagram for the system shown in Fig Q2 (a) below, expressing all values as per-unit values. Given the system base is 50kVA.

(13 marks)

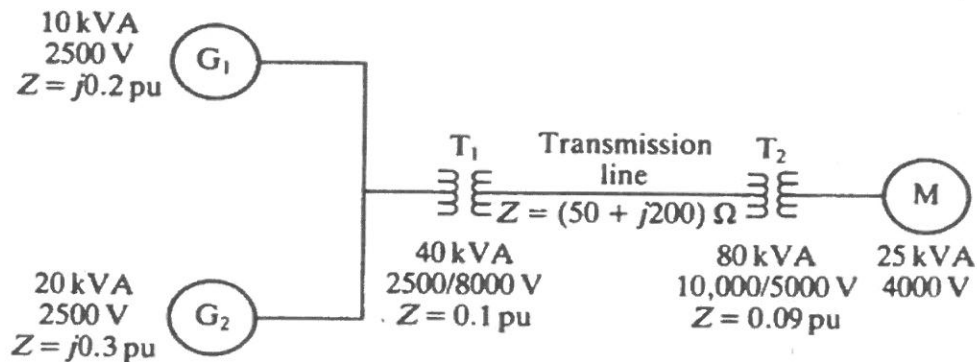

Fig Q2 (a)

- (b) A three-phase short circuit fault occurs at point F in the system shown in Fig Q2 (b) below. Calculate the fault current at point F. (12 marks)

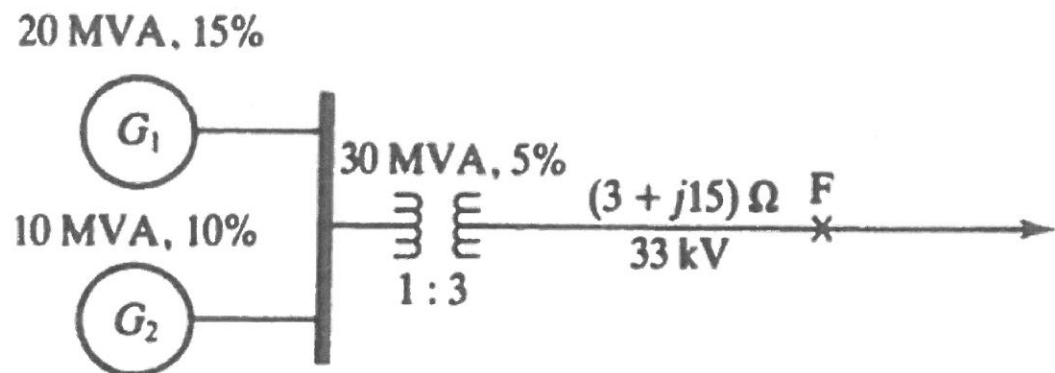

Fig Q2 (b)

Question 3

- (a) The transmission line can be represented with suitable 2-port network model. Define in terms of length and voltage magnitude the following:
- (i) short line model (2 marks)
 - (ii) medium line model (2 marks)
 - (iii) long line model (2 marks)
- (b) A 50-Hz 3-phase, 150km transmission line has the following constants:
 Resistance = 22.5Ω / phase
 Inductive reactance = 90Ω / phase
 Capacitive susceptance = $15 \times 10^{-4} \text{ S}$ / phase
 Using a π -model transmission line and ABCD matrix parameter, calculate the following when the line is used in supplying a balanced load of 40,000 kW at 110-kV, 0.8 p.f. lagging:
- (i) Sending end voltage (9 marks)
 - (ii) Sending end current (5 marks)
 - (iii) Power factor at the sending end (2 marks)
 - (iv) Efficiency of transmission (3 marks)

Question 4

- (a) A 230 kV line is fed through a 23/230 kV step-up transformer from a 23 kV supply **at sending end**. At the load end of the line, the voltage is step-down by another transformer of nominal ratio 230/23 kV. The total impedance of the line and transformers at 230 kV is $18 + j60 \Omega$. Both transformers are equipped with tap-changing facilities which are arranged so that the product of the two off-nominal settings is unity. If the load on the system is 150 MVA at 0.8 pf lagging, calculate the settings of the tap changer required to maintain the voltage of the load busbar at 23 kV.
Use base power of 150 MVA. (13 marks)
- (b) A single core cable has a conductor radius r , internal radius of sheath R and V is the potential of the conductor relative to sheath. Prove that the potential gradient g_{max} will have a minimum value when $\frac{R}{r} = e$. (6 marks)
- (c) Calculate the economic size of a single core cable in which $g_{max} = 25,000$ V/cm and operating voltage is 50 kV. (6 marks)

Question 5

The variable operating cost of three generating units are given by

$$F_1 = 500 + 5.3P_1 + 0.004P_1^2 \quad \text{RM/hr}$$

$$F_2 = 400 + 5.5P_2 + 0.006P_2^2 \quad \text{RM/hr}$$

$$F_3 = 200 + 5.8P_3 + 0.009P_3^2 \quad \text{RM/hr}$$

Where P_1, P_2 and P_3 are in MW.

Given the total load demand is 800 MW. Neglecting line losses and generator limits, determine the:

- (i) Incremental operation cost. (8 marks)
- (ii) Power output of each generating unit. (10 marks)
- (iii) The total operating cost, F_T . (7 marks)

Question 6

- (a) Explain the following tariff:
- (i) Simple tariff (5 marks)
- (ii) Sliding scale tariff (5 marks)
- (iii) Two-part tariff (5 marks)

- (b) The output of a generating station is 390×10^6 kWh per year and the installed capacity is 80 MW. Given the annum fixed charges are RM18 per kW of installed capacity and the running charges are RM0.05 per kWh. Calculate:
- (i) Annum fixed charges. (3 marks)
 - (ii) Annum running charges (3 marks)
 - (iii) Cost per kWh at the generating station (4 marks)

~The End~

EEE2113(f) _13 AUG 2019

Summary of Equations:

Alternative Energy Sources

$P_w = \frac{1}{2} \rho A v^3 \eta$	(wind power)
$TSR = \frac{4\pi}{n}$	(tip speed ratio)
$E_{\text{potential}} = mgH$	(potential energy in water)
Power (kW) approximately = $9.81 Q H \rho$	(power in water)
Avogadro's constant = 6.023×10^{23} per mole	
1 eV = 1.602×10^{-19} Watt-sec (Joules)	
$\eta = P_m / (E \times A_c)$	(solar panel efficiency)
$P = (\rho g^2 / 64\pi) H^2 m_0 T_e$	(wave power)

Load Study

$$\text{average demand}(W) = \frac{\text{total energy demand}(W \cdot \text{hr})}{\text{total time}(hr)}$$

$$\text{load factor} = \frac{\text{average demand}(W)}{\text{maximum demand}(W)}$$

$$\text{demand factor} = \frac{\text{maximum demand}(W)}{\text{total connected load}(W)}$$

$$\text{diversity factor} = \frac{\text{sum of individual maximum demand}(W)}{\text{maximum demand on power station}(W)}$$

$$\text{plant capacity factor(plant factor)} = \frac{\text{average demand on the plant}(W)}{\text{total plant capacity}(W)}$$

$$\text{plant use factor(utilization factor)} = \frac{\text{actual energy produced}(W \cdot \text{hr})}{\text{plant capacity}(W) \times \text{total time}(hr)}$$

Per Unit System

$$Z_{pu(new)} = Z_{pu(old)} \times \left(\frac{V_{b(old)}}{V_{b(new)}} \right)^2 \times \frac{VA_{base(new)}}{VA_{base(old)}} \quad \text{(changing per unit value from one base reference to another base reference)}$$

Transmission Line Model

$\begin{bmatrix} V_S \\ I_S \end{bmatrix} = \begin{bmatrix} 1 & Z \\ 0 & 1 \end{bmatrix} \begin{bmatrix} V_R \\ I_R \end{bmatrix}$	(short line model)
$\begin{bmatrix} V_S \\ I_S \end{bmatrix} = \begin{bmatrix} 1 + \frac{YZ}{2} & Z \\ Y + \frac{Y^2 Z}{4} & 1 + \frac{YZ}{2} \end{bmatrix} \begin{bmatrix} V_R \\ I_R \end{bmatrix}$	(π model)
$\begin{bmatrix} V_S \\ I_S \end{bmatrix} = \begin{bmatrix} 1 + \frac{YZ}{2} & Z + \frac{YZ^2}{4} \\ Y & 1 + \frac{YZ}{2} \end{bmatrix} \begin{bmatrix} V_R \\ I_R \end{bmatrix}$	(T model)
$\begin{bmatrix} V_S \\ I_S \end{bmatrix} = \begin{bmatrix} \cosh \gamma l & Z_c \sinh \gamma l \\ \frac{1}{Z_c} \sinh \gamma l & \cosh \gamma l \end{bmatrix} \begin{bmatrix} V_R \\ I_R \end{bmatrix}$	(long, rigorous model)

Transmission Line Parameters

$L = 2 \times 10^{-7} \ln (GMD/GMR_L) \text{ H/m}$ (inductance)
 $C = 2 \pi \epsilon / \ln (GMD/GMR_C) \text{ F/m}$ (capacitance)

Cable Grading

$g = \frac{V_{12}}{x \cdot \ln\left(\frac{D_2}{D_1}\right)}$ (dielectric stress)
 $V_n = g_{max} r_{n-1} \ln\left(\frac{r_n}{r_{n-1}}\right) ; n = 1, 2, 3 \dots$ (voltage distribution)

Optimal Dispatch

$\lambda = \frac{P_D + \sum_{i=1}^n \frac{\beta_i}{2\gamma_i}}{\sum_{i=1}^n \frac{1}{2\gamma_i}}$ (incremental cost)
 $P_i = \frac{\lambda - \beta_i}{2\gamma_i}$ (power output)

Voltage Control Method

$t_s = \sqrt{\frac{\frac{|V_1(pu)|}{|V_2(pu)|}}{1 - \frac{R(pu)P(pu) + X(pu)Q(pu)}{|V_1(pu)||V_2(pu)|}}}$ (tap-changing transformer adjustment ratio)