



**INTI**  
International College Penang

**FINAL**  
Examination Paper

(COVER PAGE)

Session : April 2019

Programme : Diploma in Electrical and Electronic Engineering (DEEI)

Course : EEE 2114: Introduction to Embedded Systems

Date of Examination : 29 July 2019 (Monday)

Time : 11:00am – 1:00pm Reading Time : Nil

Duration : 2 Hours

Special Instructions :

This paper consists of **SIX (6)** questions. Answer any **FOUR (4)** questions in the answer booklet provided. All questions carry equal marks.

**IMPORTANT NOTE : THIS PAPER SHOULD NOT BE TAKEN OUT OF THE EXAMINATION HALL**

Materials permitted :

Non-Programmable Scientific Calculator

Materials provided :

Appendix A, Appendix B & Appendix C

Examiner(s) :

Mr. Steven Khoo Boo Tap

Moderator :

Dr. Ooi Beng Lee

*This paper consists of 12 printed pages, including the cover page.*

## INTI INTERNATIONAL COLLEGE PENANG

DIPLOMA IN ELECTRICAL AND ELECTRONIC ENGINEERING PROGRAMME (DEEI)  
 EEE2114: INTRODUCTION TO EMBEDDED SYSTEMS  
 FINAL EXAMINATION: APRIL 2019 SESSION

**Instructions:** This paper consists of **SIX (6)** questions. Answer any **FOUR (4)** questions in the answer booklet provided. All questions carry equal marks.

**Question 1**

- (a) Differentiate between PIC16F628A microcontroller and PIC16F877A microcontroller by completing Table 1a as shown below.

Table 1a Comparison between PIC16F628A and PIC16F877A microcontroller

Description	PIC16F628A	PIC16F877A
Ports (Number of Bits) E.g. Port A(2)		
Number of Analog Pins		
Total I/O Pins		
Data Memory (Bytes)		
Program Flash (Words)		
Data EEPROM (Bytes)		
ADC-bit (Channel)		
CCP (PWM)		
SSP		
Internal Oscillator (Hz)		

(10 marks)

- (b) Given the Special Function Registers and File Registers for PIC16F877A microcontroller as follows:

Table 1(b-1) Special Function Registers

Update	Address	Symbol Name	Value
		WREG	0x23
	003	STATUS	0x1F
	004	FSR	0x70
	006	PORTB	0x00
	086	TRISB	0xFF

Table 1(b-2) File Registers

Address	00	01	02	03	04	05	06	07	08	09	0A	0B	0C	0D	0E	0F
000	00	00	00	1F	70	00	00	--	--	--	16	77	00	--	00	00
010	10	20	00	--	--	00	55	33	60	00	00	--	--	--	--	00
020	61	12	10	56	34	18	52	AA	11	33	22	44	50	60	78	80
030	14	24	34	45	54	64	74	84	94	A4	B4	C4	D4	E4	F4	04
040	21	31	41	51	62	71	81	91	01	02	03	04	05	06	07	08
050	09	0A	0B	0C	0D	0E	0F	F0	F1	F2	F3	F4	F5	F6	F7	F8
060	42	46	47	48	49	56	85	57	58	59	5A	5B	5C	5D	5E	5F
070	63	65	66	67	68	69	6A	6B	6C	6D	6E	6F	72	73	74	75
080	00	FF	00	1F	70	FF	00	--	--	--	16	77	70	--	08	--
090	--	--	FF	--	--	--	--	--	02	79	7A	7B	0C	00	--	6E
0A0	82	83	84	85	86	87	88	89	8A	8B	8C	8D	8E	8F	92	93
0B0	94	95	96	97	98	99	9A	9B	9C	9D	9E	9F	9E	A0	B0	C0
0C0	E0	F0	A1	A2	A3	A4	A5	A6	A7	A8	A9	AA	AB	AC	AD	AE
0D0	30	05	06	07	35	08	09	0A	0B	0C	0D	0E	0F	19	90	70

(All data of File Register are hexadecimal)

Perform the following short programs. Elaborate the result of the affected register(s) and Status (Z, DC and C) as shown in Table 1(b-3) using **Before** and **After** the execution of each instruction. The questions are independent of each other but the instructions are linked within the question.

Table 1(b-3) Before and After

Instruction	Before						After					
	W	FSR	70H	Z	DC	C	W	FSR	70H	Z	DC	C
ANDLW 0'17'	23	70	63	1	1	1						
COMF FSR, W												

- (i) ANDLW 0'17'
- COMF FSR, W
- RRF FSR, 1
- ADDWF INDF, 0
- SWAPF 41H, F

(5 marks)

- (ii) MOVLW .32
- RLF FSR, 0
- ADDWF INDF, 1
- IORWF 0x2A, F
- DECF d'66', W

(5 marks)

- (iii) MOVF b'111110', 0
- SUBWF INDF, 1
- XORWF FSR, F
- SWAPF 43, 1
- INCF INDF, W

(5 marks)

## Question 2

- (a) Table 2(a) assembly program will be built using MPLAB X IDE with MPASMWIN assembler. Study and analyze the Assembly Language Codes given below written using PIC16F877A microcontroller and answer the following questions.

Table 2(a) PIC16F877A Assembly Coding

Line 1	INCLUDE <P16F877A.inc>
Line 2	__CONFIG 3F3AH
Line 3	C EQU 0x0
Line 4	ORG 0
Line 5	movf 22H,W
Line 6	addwf 32,0
Line 7	bt fss 3,C
Line 8	goto NC
Line 9	clf 0x41,1
Line 10	incf 41H,F
Line 11	movwf .66
Line 12	movf b'100001',0
Line 13	addwf h'31',W
Line 14	addwf 41h,1
Line 15	goto A
Line 16	Nc movwf o'102'
Line 17	movf 21H,0
Line 18	addwf 0x31,W
Line 19	movwf d'65'
Line 20	A goto A
Line 21	END

- (i) Identify significant **ERROR(S)** in the instructions of Table 2(a) that will caused the assembler to output "BUILD FAILED" when build all. Explain why it is incorrect and write the correct codes according to the Assembly Language format. Indicate the Line number of the error code as well. (3 marks)
- (ii) Based on the assumption that all lines of codes are corrected, describe the function of the program and also provide a sample final result of Table 2(a) program after correction. (4 marks)
- (iii) Modify the program in Table 2(a) to less than 13 lines of coding but still perform the same outcome as the original function of the coding. Hint: The improved full program should be less than 13 lines of coding instead of 21 lines. (8 marks)

- (b) Figure 2(b) shows output connection of PIC16F628A microcontroller driving 4 LEDs in parallel configuration. Analyze if the circuit is going to work when Port B, RB1 is outputting a High or Logic 1? Referring to the Electrical Characteristics of the microcontroller as shown in Table 2(b), justify your explanation with calculation whether Figure 2(b) configuration is going to work or not. If not, then provide a solution. (10 marks)

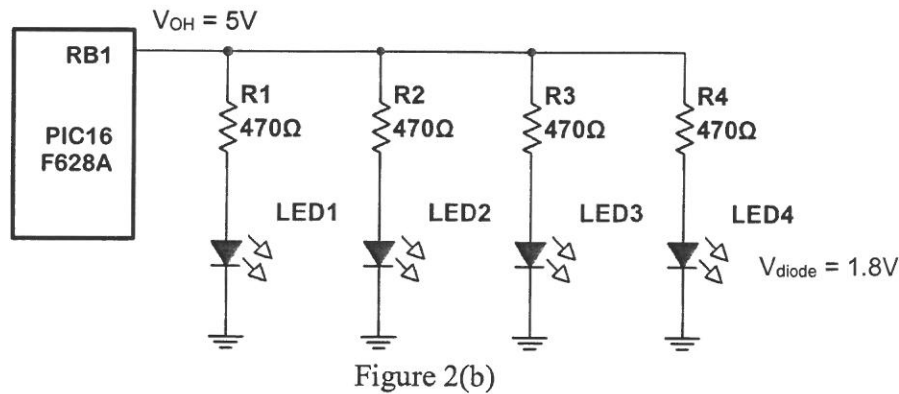

Table 2(b) Electrical Characteristics

Absolute Maximum Ratings †	
Ambient temperature under bias.....	-55 to +125°C
Storage temperature .....	-65°C to +150°C
Voltage on any pin with respect to V <sub>SS</sub> (except V <sub>DD</sub> , $\overline{MCLR}$ , and RA4) .....	-0.3V to (V <sub>DD</sub> + 0.3V)
Voltage on V <sub>DD</sub> with respect to V <sub>SS</sub> .....	-0.3 to +7.5V
Voltage on $\overline{MCLR}$ with respect to V <sub>SS</sub> (Note 2) .....	0 to +14V
Voltage on RA4 with respect to V <sub>SS</sub> .....	0 to +8.5V
Total power dissipation (Note 1) .....	1.0W
Maximum current out of V <sub>SS</sub> pin .....	300 mA
Maximum current into V <sub>DD</sub> pin .....	250 mA
Input clamp current, I <sub>IK</sub> (V <sub>I</sub> < 0 or V <sub>I</sub> > V <sub>DD</sub> ).....	± 20 mA
Output clamp current, I <sub>OK</sub> (V <sub>O</sub> < 0 or V <sub>O</sub> > V <sub>DD</sub> ).....	± 20 mA
Maximum output current sunk by any I/O pin.....	25 mA
Maximum output current sourced by any I/O pin .....	25 mA
Maximum current sunk by PORTA, PORTB and PORTE (combined) (Note 3).....	200 mA
Maximum current sourced by PORTA, PORTB and PORTE (combined) (Note 3).....	200 mA
Maximum current sunk by PORTC and PORTD (combined) (Note 3) .....	200 mA
Maximum current sourced by PORTC and PORTD (combined) (Note 3) .....	200 mA

**Note 1:** Power dissipation is calculated as follows:  $P_{dis} = V_{DD} \times \{I_{DD} - \sum I_{OH}\} + \sum \{(V_{DD} - V_{OH}) \times I_{OH}\} + \sum (V_{OL} \times I_{OL})$

**Note 2:** Voltage spikes below V<sub>SS</sub> at the  $\overline{MCLR}$  pin, inducing currents greater than 80 mA, may cause latch-up. Thus, a series resistor of 50-100Ω should be used when applying a "low" level to the  $\overline{MCLR}$  pin rather than pulling this pin directly to V<sub>SS</sub>.

**Note 3:** PORTD and PORTE are not implemented on PIC16F873A/876A devices.

† NOTICE: Stresses above those listed under "Absolute Maximum Ratings" may cause permanent damage to the device. This is a stress rating only and functional operation of the device at those or any other conditions above those indicated in the operation listings of this specification is not implied. Exposure to maximum rating conditions for extended periods may affect device reliability.

**Question 3**

- (a) “An embedded system can be a very simple piece of electronic circuitry that performs a specific function within a larger system”. Describe how a computer mouse can be an example of embedded systems applications. (5 marks)
- (b) Describe the serial communications used in PIC microcontroller shown in Figure 3(b). Provide TWO (2) comparisons between SPI mode and I<sup>2</sup>C mode. (8 marks)

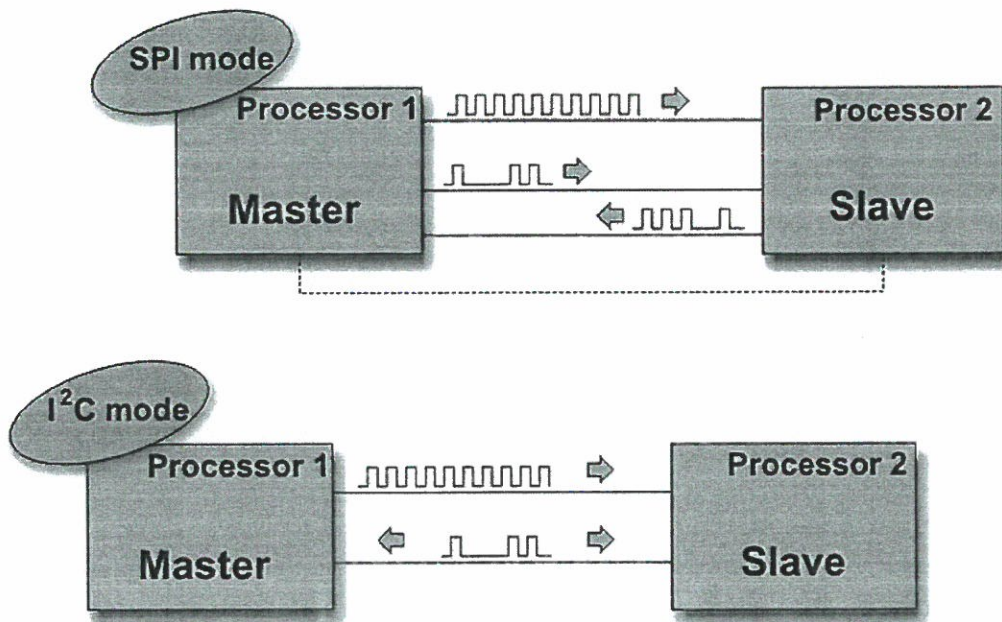

Figure 3(b)

- (c) The TXTSA Register and RCSTA Register of a PIC16F877A microcontroller is set as shown in Table 3(c-1) and Table 3(c-2) respectively. Table 3(c-3) indicates the setting required for configuring the 9600 baud rate for 4 MHz oscillator at high speed operating in asynchronous mode using 8-bit data. Assume that there is no error and awaiting for the data being to be transmitted.

Table 3(c-1) TXTSA register.

TXTSA Register	bit 7	bit 6	bit 5	bit 4	bit 3	bit 2	bit 1	bit 0
	0	0	1	0	0	1	0	0

Table 3(c-2) RCSTA register.

RCSTA Register	bit 7	bit 6	bit 5	bit 4	bit 3	bit 2	bit 1	bit 0
	1	0	0	0	0	0	0	0

Table 3(c-3) SPBRG register.

SPBRG Register	bit 7	bit 6	bit 5	bit 4	bit 3	bit 2	bit 1	bit 0
	?	?	?	?	?	?	?	?

Table 3(c-4) Baud rate formula.

SYNC	BRGH = 0 (Low Speed)	BRGH = 1 (High Speed)
0	(Asynchronous) Baud Rate = $F_{osc}/(64(X + 1))$	Baud Rate = $F_{osc}/(16(X + 1))$
1	(Synchronous) Baud Rate = $F_{osc}/(4(X + 1))$	N/A

Legend: X = value in SPBRG (0 to 255)

[Refer to Appendix]

- (i) Describe in details the setting used for TXSTA register. (4 marks)
- (ii) Describe in details the setting used for RCSTA register. (4 marks)
- (iii) Determine the setting used for SPBRG register. Show the calculation working clearly. (4 marks)

**Question 4**

- (a) Describe the following terms used in the characteristic of an embedded system:
  - (i) Fault-Tolerance (3 marks)
  - (ii) Portability (3 marks)
  - (iii) Real-Time (3 marks)

- (b) Figure 4(b) shows the PIC16F877A to PIC16F877A communication via Universal Synchronous Receiver Transmitter (UART). Describe the UART communication between these two PIC microcontrollers. State on the typical baud rate used for this communication. Assume the communication protocol used is 8N1. Figure 4(b) shows communication between two PIC16F877A microcontrollers.

(7 marks)

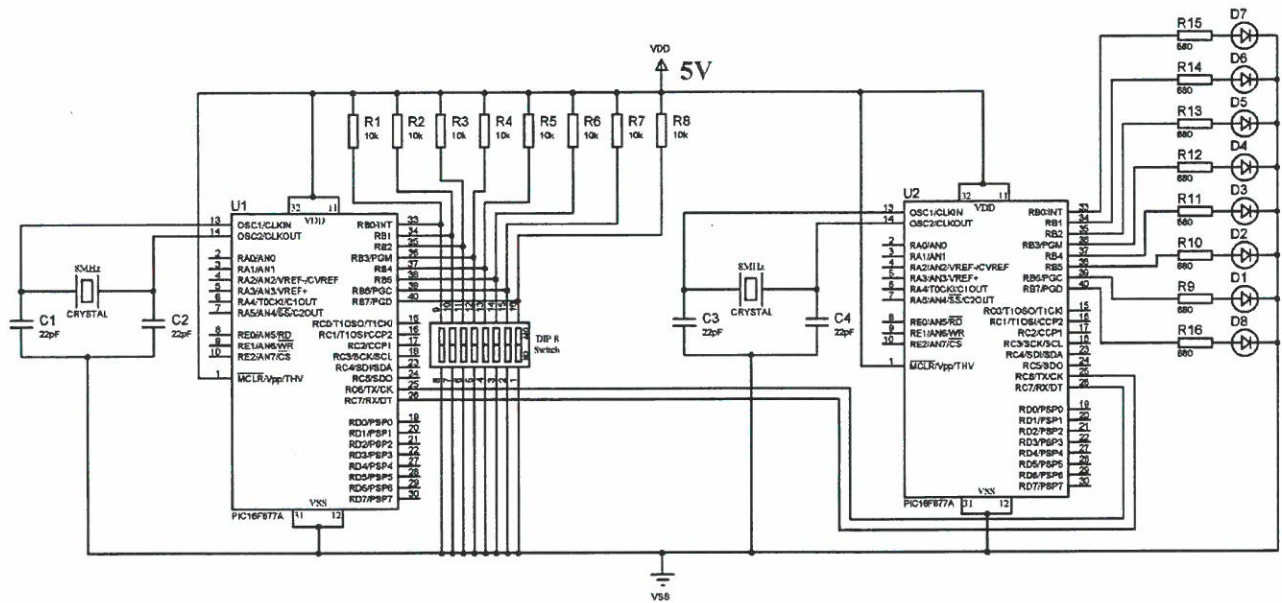

Figure 4(b)

- (c) A PIC16F628A microcontroller was setup to read some digital signals from PORTA as shown in Table 4(c-1) but it did not work. However, the program work after changing to Table 4(c-2). Explain why it does not work in the first place but work after the changes. Describe the function of the program in Table 4(c-2).

(9 marks)

Table 4(c-1) Initial Program.

Instruction	
CLRF	PORTA
BCF	STATUS, RP1
BSF	STATUS, RP0
MOVLW	0xFF
MOVWF	TRISA

Table 4(c-2) Changed Program.

Instruction	
CLRF	PORTA
MOVLW	0x07
MOVWF	CMCON
BCF	STATUS, RP1
BSF	STATUS, RP0
MOVLW	0x1F
MOVWF	TRISA

**Question 5**

- (a) A Timer 2 block diagram is shown in Figure 5(a). Timer 2 is used to generate a delay of  $60\mu\text{s}$ .
- (i) Determine the value of the PR2 if the TMR2 is 0, the prescaler and postscaler of 1:1 are selected. Assume that the crystal clock is running at the frequency of 16MHz. Ignore the overhead due to instructions in the calculation. (5 marks)
- (ii) Explain how the microcontroller knows the delay of  $60\mu\text{s}$  has reached. (3 marks)

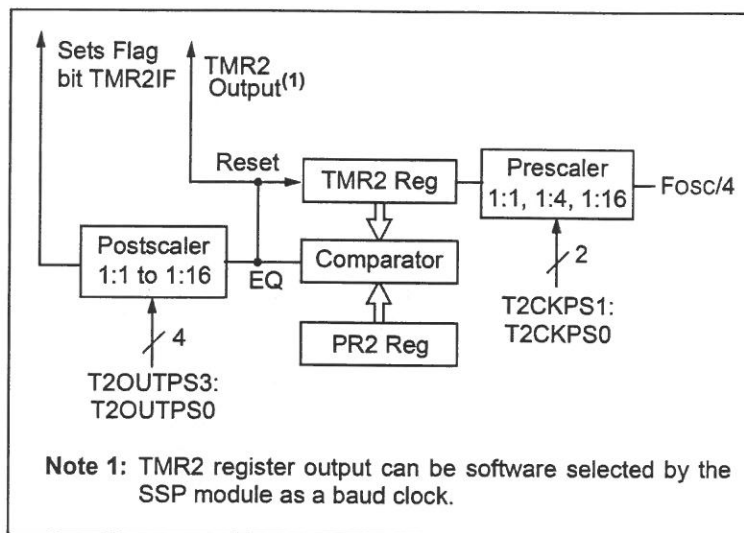

Figure 5(a)

- (b) Explain THREE (3) types of memories available in the Peripheral Interface Controller (PIC) microcontroller and how each of them are being used by the programmer. The description should include the size and the range of each memory explained. State the possible type of microcontroller used for Figure 5(b-2). Also, explain the amount of memory left in Data memory and Program memory of Figure 5(b-2). (9 marks)

Flash Program Memory (14-bit words)
Data Memory (bytes)
EEPROM Data Memory (bytes)

Figure 5(b-1)

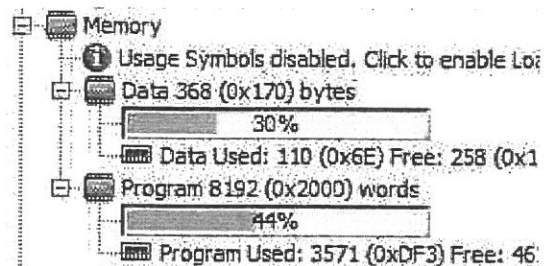

Figure 5(b-2)

- (c) The PIC16F877A analogue to digital converter (ADC) is being configured. In this design, an internal voltage reference is selected, input channel 3 is selected, and the ADC is switched on but not running. Assume that channel 0, channel 1, channel 2 and channel 4 are configured as analogue input only. Also, assume that the conversion clock used is  $F_{osc}/4$  with left justification on the result.

[Refer to Appendix]

- (i) Determine the setting for the ADCON0 register. (2 marks)
- (ii) Determine the setting for the ADCON1 register. (2 marks)
- (iii) Give one advantage of using an internal voltage reference or an external voltage reference. (4 marks)

### Question 6

- (a) The INTCON Register of a PIC16F628A microcontroller is set as shown in Table 6(a-1).

Table 6(a-1) Initial INTCON register.

INTCON Register	bit 7	bit 6	bit 5	bit 4	bit 3	bit 2	bit 1	bit 0
	1	0	1	0	1	0	0	0

- (i) Determine which interrupts are enabled.
- (ii) An interrupt occurs and the INTCON register is found to have changed to the setting shown in Table 6(a-2). Which interrupt source has called?

Table 6(a-2) After interrupt occurred.

INTCON Register	bit 7	bit 6	bit 5	bit 4	bit 3	bit 2	bit 1	bit 0
	1	0	1	0	1	0	0	1

[Refer to Appendix]

(5 marks)

- (b) Compare the operation of Figure 6(b-1) architecture with Figure 6(b-2) architecture. Name the architecture for Figure 6(b-1) and Figure 6(b-2). (4 marks)

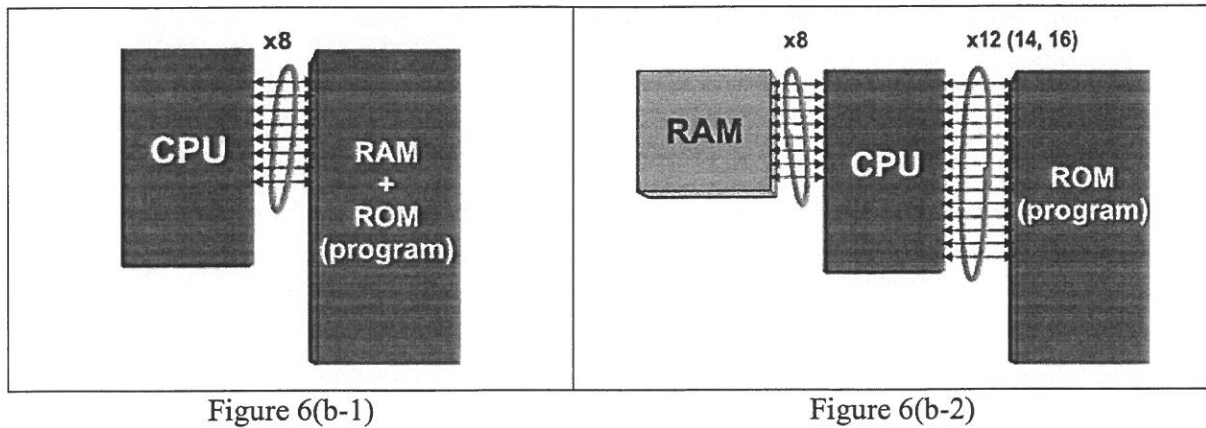

- (c) Name and describe the function of the following labels as shown in Figure 6(c).

- (i) Label (A) (3 marks)
- (ii) Label (B) (3 marks)
- (iii) Label (C) (3 marks)
- (iv) Label (D) (3 marks)
- (v) Label (E) (3 marks)

State the possible type of microcontroller for Figure 6(c) internal architecture.

(1 mark)

