



INTI
International College Penang

FINAL
Examination Paper

(COVER PAGE)

Session : April 2019

Programme : Diploma in Electrical and Electronic Engineering (DEEL)

Course : EEE 2113: Electric Power Systems and Machines

Date of Examination : 31 July 2019 (Wednesday)

Time : 11:00am – 1:00pm Reading Time : Nil

Duration : 2 Hours

Special Instructions :

This paper consists of **SIX (6)** questions. Answer any **FOUR (4)** questions in the answer booklet provided. All questions carry equal marks.

IMPORTANT NOTE : THIS PAPER SHOULD NOT BE TAKEN OUT OF THE EXAMINATION HALL

Materials permitted :
Non-Programmable Scientific Calculator

Materials provided :
Nil

Examiner(s) : Mr. Alan Wong Kam Mun

Moderator : Dr. Ooi Beng Lee

This paper consists of 7 printed pages, including the cover page.

INTI INTERNATIONAL COLLEGE PENANG
DIPLOMA IN ELECTRICAL AND ELECTRONIC ENGINEERING PROGRAMME (DEEI)
EEE 2113: ELECTRIC POWER SYSTEMS AND MACHINES
FINAL EXAMINATIONS: APRIL 2019 SESSION

Instructions: This paper consists of **SIX (6)** questions. Answer any **FOUR (4)** questions in the answer booklet provided. All questions carry equal marks.

Question 1

(a) A generating station has the following daily loads:

Time(24hrs)	0 – 6	6 – 10	10 – 12	12 - 16	16 - 20	20 - 24
Load(MW)	40	50	60	50	70	40

- (i) Draw the load curve. (5 marks)
- (ii) Find maximum demand. (2 marks)
- (iii) Units of energy generated per day. (4 marks)
- (iv) Average load. (2 marks)
- (v) Load factor. (2 marks)
- (b) A base load station having a capacity of 18MW is sharing a common load with a standby station having a capacity of 25MW. Given:
- Annual standby station output = 7.5×10^6 kWh.
 - Annual base load station output = 110×10^6 kWh.
 - Peak load on standby station = 15MW.
 - Hours of use of standby station/year = 2290 hours.
 - Hours of use of base load station/year = 8760 hours. Calculate:
- (i) Standby station annual load factor. (6 marks)
- (ii) Standby station annual capacity factor. (4 marks)

Question 2

- (a) Draw an impedance diagram for the system shown in Fig Q2 (a) below, expressing all values as percent values. Given the system base is 10MVA. (13 marks)

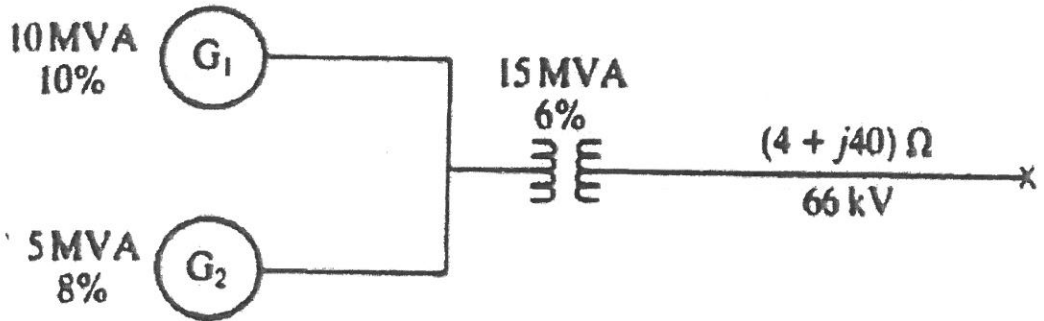

Fig Q2 (a)

- (b) An interconnected generator-reactor system shown in Fig Q2 (b) below. The base values for the given percent reactances are the ratings of the individual pieces of equipment. A three-phase short-circuit occurs at point F. Given the busbar line to line voltage is 11kV. Use 50 MVA as the base MVA.

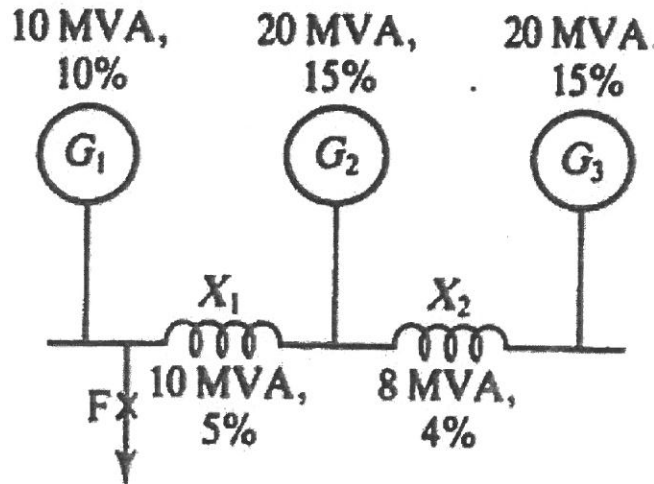

Fig Q2 (b)

- (i) Determine the fault current and the fault kVA. (12 marks)

Question 3

- (a) The transmission line can be represented with suitable 2-port network model. Define in terms of length and voltage magnitude the following:
- (i) short line model (2 marks)
 - (ii) medium line model (2 marks)
 - (iii) long line model (2 marks)

- (b) A 210kV, 150MVA, 60-Hz 3-phase, 140km transmission line has the following constants:
 Resistance = 16.8Ω / phase
 Inductive reactance = 123.2Ω / phase
 Capacitive susceptance = $5.74 \times 10^{-4} \text{ S}$ / phase
 Using a π -model transmission line and ABCD matrix parameter, calculate the following when the line is used in supplying a balanced load of 150MVA at 210kV, 0.85 p.f. lagging:
- (i) Sending end voltage (9 marks)
 - (ii) Sending end current (5 marks)
 - (iii) Power factor at the sending end (2 marks)
 - (iv) Efficiency of transmission (3 marks)

Question 4

- (a) A 132 kV line is fed through a 11/132 kV step-up transformer from a 11 kV supply at the send side. At the load end of the line, the voltage is step-down by another transformer of nominal ratio 132/11 kV. The total impedance of the line and transformers at 132 kV is $25 + j66 \Omega$. Both transformers are equipped with tap-changing facilities which are arranged so that the product of the two off-nominal settings is unity ($t_s t_r = 1$). If the load on the system is 100 MVA at 0.9 pf lagging, calculate the settings of the tap changers required to maintain the voltage of the load busbar at 11 kV. Use base power of 100 MVA. (13 marks)
- (b) A single core cable has a conductor radius r , internal radius of sheath R and V is the potential of the conductor relative to sheath. Prove that the potential gradient g_{max} will have a minimum value when $\frac{R}{r} = e$. (6 marks)
- (c) Calculate the economic size of a single core cable in which $g_{max} = 15,000 \text{ V/cm}$ and operating voltage is 50 kV. (6 marks)

Question 5

The variable operating cost of three generating units are given by

$$F_1 = 350 + 7.2P_1 + 0.004P_1^2 \text{ RM/hr}$$

$$F_2 = 500 + 7.3P_2 + 0.0025P_2^2 \text{ RM/hr}$$

$$F_3 = 600 + 6.74P_3 + 0.003P_3^2 \text{ RM/hr}$$

Where P_1, P_2 and P_3 are in MW.

Given the total load demand is 450 MW. Neglecting line losses and generator limits, determine the:

- (i) Incremental operation cost. (8 marks)
- (ii) Power output of each generating unit. (10 marks)
- (iii) The total operating cost, F_T . (7 marks)

Question 6

- (a) Explain the following tariff:
 - (i) Flat-rate tariff (5 marks)
 - (ii) Block rate tariff (5 marks)
 - (iii) Power factor tariff (5 marks)
- (b) Given the block rate tariff as follows:
 - First 50kWh at RM0.60 per kWh
 - Next 50kWh at RM0.50 per kWh
 - Excess over 100kWh at RM0.25 per kWh
 - If 275kWh is consumed, compute:
 - (i) Total cost of electrical energy. (8 marks)
 - (ii) The average cost/ kWh (2 marks)

~The End~

EEE2113 APRIL2019/21-3-2019

Summary of Equations:

Alternative Energy Sources

$P_w = \frac{1}{2} \rho A v^3 \eta$	(wind power)
$TSR = \frac{4\pi}{n}$	(tip speed ratio)
$E_{\text{potential}} = mgH$	(potential energy in water)
Power (kW) approximately = 9.81 Q H ρ	(power in water)
Avogadro's constant = 6.023×10^{23} per mole	
1 eV = 1.602×10^{-19} Watt-sec (Joules)	
$\eta = P_m / (E \times A_c)$	(solar panel efficiency)
$P = (\rho g^2 / 64 \pi) H^2 m_0 T_e$	(wave power)

Load Study

$average\ demand(W) = \frac{total\ energy\ demand\ (W \cdot hr)}{total\ time\ (hr)}$	
$load\ factor = \frac{average\ demand(W)}{maximum\ demand(W)}$	
$demand\ factor = \frac{maximum\ demand(W)}{total\ connected\ load(W)}$	
$diversity\ factor = \frac{sum\ of\ individual\ maximum\ demand(W)}{maximum\ demand\ on\ power\ station\ (W)}$	
$plant\ capacity\ factor(plant\ factor) = \frac{average\ demand\ on\ the\ plant(W)}{total\ plant\ capacity(W)}$	
$plant\ use\ factor(utilization\ factor) = \frac{actual\ energy\ produced(W \cdot hr)}{plant\ capacity(W) \times total\ time(hr)}$	

Per Unit System

$Z_{pu(new)} = Z_{pu(old)} \times \left(\frac{V_{b(old)}}{V_{b(new)}} \right)^2 \times \frac{VA_{base(new)}}{VA_{base(old)}}$	(changing per unit value from one base reference to another base reference)
--	---

Transmission Line Model

$\begin{bmatrix} V_S \\ I_S \end{bmatrix} = \begin{bmatrix} 1 & Z \\ 0 & 1 \end{bmatrix} \begin{bmatrix} V_R \\ I_R \end{bmatrix}$	(short line model)
$\begin{bmatrix} V_S \\ I_S \end{bmatrix} = \begin{bmatrix} 1 + \frac{YZ}{2} & Z \\ Y + \frac{Y^2 Z}{4} & 1 + \frac{YZ}{2} \end{bmatrix} \begin{bmatrix} V_R \\ I_R \end{bmatrix}$	(π model)
$\begin{bmatrix} V_S \\ I_S \end{bmatrix} = \begin{bmatrix} 1 + \frac{YZ}{2} & Z + \frac{YZ^2}{4} \\ Y & 1 + \frac{YZ}{2} \end{bmatrix} \begin{bmatrix} V_R \\ I_R \end{bmatrix}$	(T model)
$\begin{bmatrix} V_S \\ I_S \end{bmatrix} = \begin{bmatrix} \cosh \gamma l & Z_C \sinh \gamma l \\ \frac{1}{Z_C} \sinh \gamma l & \cosh \gamma l \end{bmatrix} \begin{bmatrix} V_R \\ I_R \end{bmatrix}$	(long, rigorous model)

Transmission Line Parameters

$L = 2 \times 10^{-7} \ln (GMD/GMR_L)$ H/m	(inductance)
$C = 2 \pi \epsilon / \ln (GMD/GMR_C)$ F/m	(capacitance)

Cable Grading

$$g = \frac{V_{12}}{x \cdot \ln\left(\frac{D_2}{D_1}\right)} \quad \text{(dielectric stress)}$$

$$V_n = g_{max} r_{n-1} \ln\left(\frac{r_n}{r_{n-1}}\right) ; n = 1, 2, 3 \dots \quad \text{(voltage distribution)}$$

Optimal Dispatch

$$\lambda = \frac{P_D + \sum_{i=1}^n \frac{\beta_i}{2\gamma_i}}{\sum_{i=1}^n \frac{1}{2\gamma_i}} \quad \text{(incremental cost)}$$

$$P_i = \frac{\lambda - \beta_i}{2\gamma_i} \quad \text{(power output)}$$

Voltage Control Method

$$t_s = \sqrt{\frac{\frac{|V_1(pu)|}{|V_2(pu)|}}{1 - \frac{R(pu)P(pu) + X(pu)Q(pu)}{|V_1(pu)||V_2(pu)|}}} \quad \text{(tap-changing transformer adjustment ratio)}$$

