



INTI
International College Penang
LAUREATE INTERNATIONAL UNIVERSITIES*

FINAL
Examination Paper

(COVER PAGE)

Session : April 2016

Programme : Diploma in Electrical and Electronic Engineering

Course : EEE 2114: Introduction to Embedded Systems

Date of Examination : 28 July 2016, Thursday

Time : 2.00pm – 4.00pm Reading Time : Nil

Duration : 2 Hours

Special Instructions :

This paper consists of **SIX (6)** questions. Answer any **FOUR (4)** questions in the answer booklet provided. All questions carry equal marks.

IMPORTANT NOTE : THIS PAPER SHOULD NOT BE TAKEN OUT OF THE EXAMINATION HALL

Materials permitted :
Non-Programmable Scientific Calculator

Materials provided :
Appendix A (PIC Microcontroller 14-Bit Core Instruction Set),
Appendix B (PIC16F627A/628A/648A Datasheet), Appendix C (PIC16F87XA Datasheet)

Examiner(s) : Mr. Steven Khoo Boo Tap

Moderator : Mr. Kevin Tan Geok Su

*This paper consists of **8** printed pages, including the cover page.*

INTI INTERNATIONAL COLLEGE

DIPLOMA IN ELECTRICAL AND ELECTRONIC ENGINEERING (DEEI)
 EEE2114: INTRODUCTION TO EMBEDDED SYSTEMS
 FINAL EXAMINATION: APR2016 SESSION

Instructions: This paper consists of **SIX (6)** questions. Answer any **FOUR (4)** questions in the answer booklet provided. All questions carry equal marks.

Question 1

- (a) Provide SIX (6) main differences between microprocessor and microcontroller. (6 marks)
- (b) Discuss the operation of both the Von Neumann and Harvard computer structures using appropriate diagram to illustrate your answer. Clearly distinguish between them. (6 marks)
- (c) Explain THREE (3) types of memories available in the Peripheral Interface Controller (PIC) and the role played by each of them. (6 marks)
- (d) Figure 1(d) below shows the pin configuration of PIC16F628A microcontroller. Explain how the pin RA4 and pin RA5 of PIC16F628A microcontroller can be used as output function; otherwise provide the reason why it can't. Use appropriate diagram to aid your explanation. (7 marks)

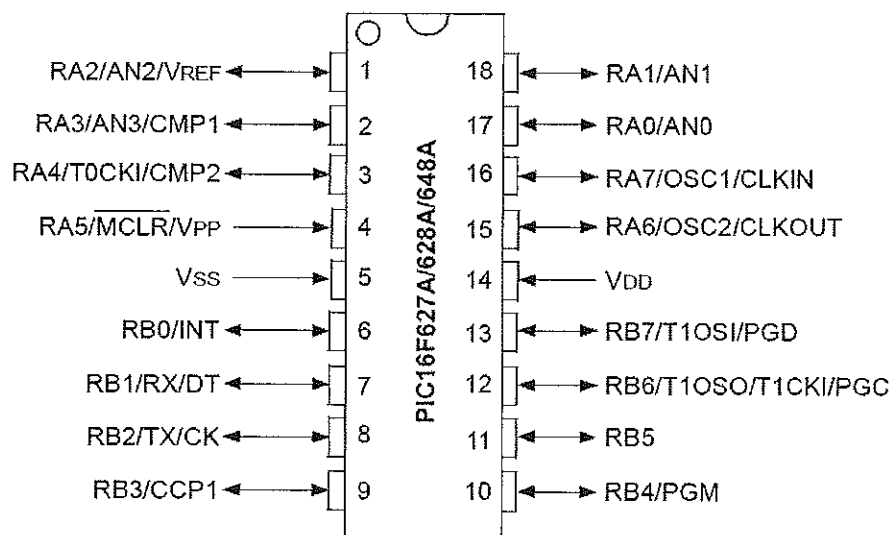

Figure 1(d)

Question 2

(a) Given the Special Function Registers and File Registers as follows:

Special Function Registers			
Update	Address	Symbol Name	Value
		WREG	32
	003	STATUS	0x19
	004	FSR	01010101
	005	PORTA	0x00
	006	PORTB	0x00
	011	TMR2	0x25

File Registers																
Address	00	01	02	03	04	05	06	07	08	09	0A	0B	0C	0D	0E	0F
000	--	00	00	18	20	00	00	--	--	--	16	77	00	--	00	00
010	00	00	00	--	--	00	00	00	00	00	00	--	--	--	--	00
020	61	12	10	56	34	18	52	AA	11	33	22	44	50	60	78	80
030	14	24	34	45	54	64	74	84	94	A4	B4	C4	D4	E4	F4	04
040	21	31	41	51	62	71	81	91	01	02	03	04	05	06	07	08
050	09	0A	0B	0C	0D	0E	0F	F0	35	36	37	38	39	40	42	
060	42	46	47	48	49	56	85	57	58	59	5A	5B	5C	5D	5E	5F
070	63	65	66	67	68	69	6A	6B	6C	6D	6E	6F	72	73	74	75
080	--	FF	00	18	20	FF	FF	--	--	--	16	77	70	--	08	--
090	--	--	FF	--	--	--	--	--	02	79	7A	7B	0C	00	--	6E
0A0	82	83	84	85	86	87	88	89	8A	8B	8C	8D	8E	8F	92	93
0B0	94	95	96	97	98	99	9A	9B	9C	9D	9F	9E	A0	B0	C0	D0
0C0	E0	F0	A1	A2	A3	A4	A5	A6	A7	A8	A9	AA	AB	AC	AD	AE

Figure 2(a)

Perform the following operations. Indicate the result of the affected register(s) and Status (Z, DC and C). The operations are independent of each other. Show all workings of before and after with appropriate diagram illustration.

- (i) RLF FSR, W
- (ii) XORWF INDF, 1
- (iii) COMF INDF, F
- (iv) IORWF 0x53, 3
- (v) SWAPF INDF, 0
- (vi) SUBWF 0x28, 2

(18 marks)

(b) With the aid of a simple diagram, discuss the purpose and operation of the stack, when a PIC16F628A microcontroller executes a subroutine.

(7 marks)

Question 3

- (a) Describe FOUR (4) main considerations when selecting microcontroller in embedded system design. Assuming cost and memory architecture are not the main consideration. (4 marks)
- (b) Give a definition of embedded system with the aid of a diagram. (4 marks)
- (c) Describe the operation of the following assembly code snippet, and explain what the program accomplishes. (5 marks)

```

COUNT equ h'20'
movlw .10
movwf COUNT
bsf 5,0
LOOP: decf COUNT, f
      btfss 3,2
      goto LOOP
      bcf 5,0
NEXT --- ----
    
```

- (d) Figure 3(d) shows the PIC to PIC communication via UART. Briefly explain the UART communication between these 2 PIC microcontrollers. Comment on the typical baud rate used for this communication. Assume the communication protocol used is 8N1. The figure below shows communication between two PIC16F877A microcontrollers.

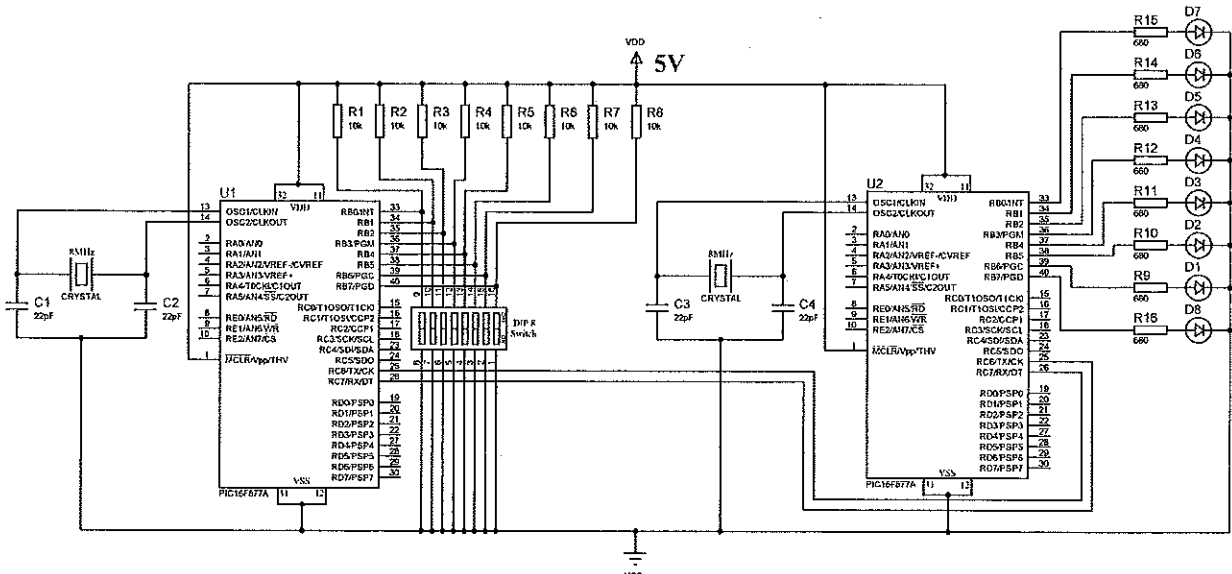

Figure 3(d)

(7 marks)

- (e) Among these THREE (3) instructions, RETURN, RETLW and RETFIE, which one is the best instruction to use for returning from Interrupt Service Routine? Why? (5 marks)

Question 4

- (a) Figure 4(a) shows part of the PIC16F877A microcontroller internal architecture.

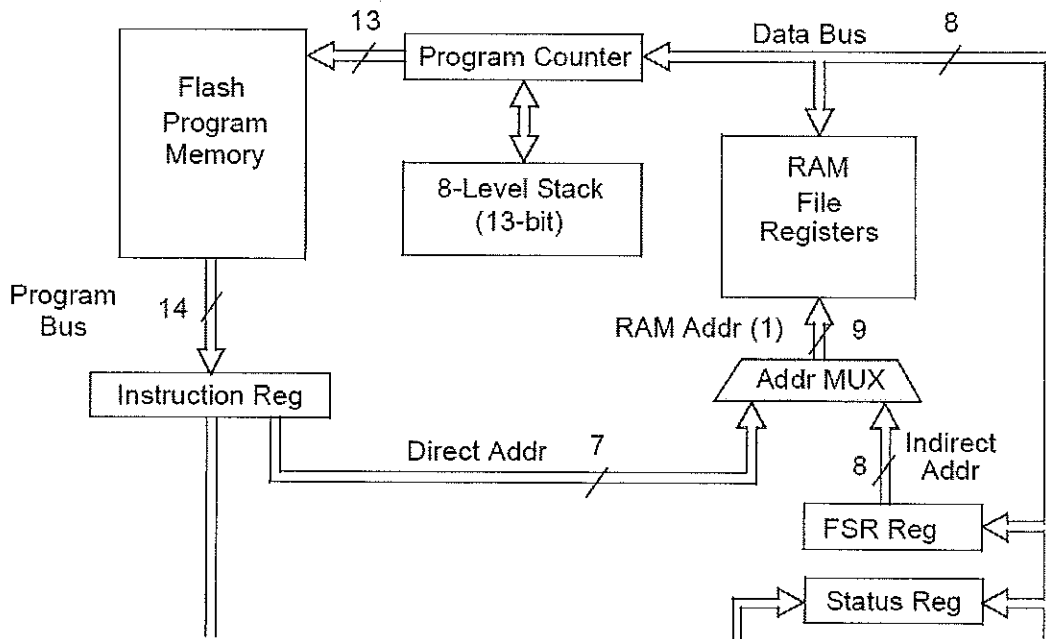

Figure 4(a)

- (i) What is the purpose of the Stack block? (2 marks)
- (ii) What is the size of each memory location in the Program Memory? Explain why such size is being used? (2 marks)
- (iii) Explain why the Program Counter is connected to the Data Bus? (2 marks)
- (b) Write a subprogram which enables external interrupt from pin RB0/INT. [Refer to Appendix for Instruction Set] (4 marks)
- (c) Pin RB4:RB7 of PIC16F877A are normally used in keypad interfacing, explain why? (3 marks)

- (d) Write a PIC assembly-level program to compare the contents in File Register 42H (to be named **NUM1**) and File Register 43H (to be named **NUM2**). If the contents are equal, add twenty onto the contents of File Register A0H (to be named **RESULT**), otherwise clear it. Assume the program is written from PIC16F877A microcontroller. [Refer to Appendix for Instruction Set] (12 marks)

Question 5

- (a) When the LCD display is not enabled, data lines are tri-state, what is meant by tri-state? (4 marks)
- (b) Refer to Figure 5(b), the LCD requires THREE (3) "Control" lines from the microcontroller, namely Enable (E), Read/Write (R/W) and Register select (RS). Describe the function of each of the line.

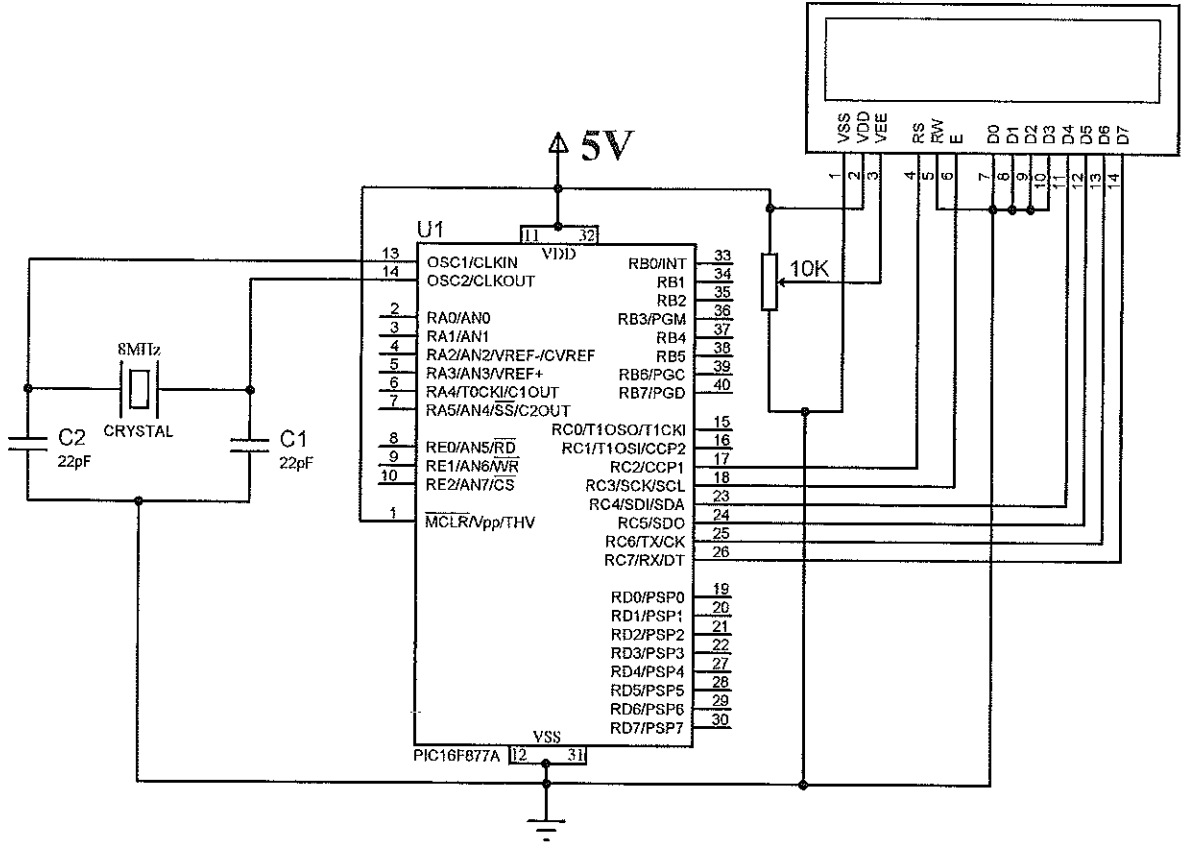

Figure 5(b)

(6 marks)

- (c) What is the function of MCLR pin used for PIC16F877A? Draw a recommended MCLR circuit where the MCLR pin no longer be tied directly to V_{DD}. (7 marks)

- (d) Calculate the time delay taken for Program 5(d) running at 8-MHz oscillator by the PIC16F628A microcontroller. Short all workings clearly for each instruction. (8 marks)

Program	
DELAY:	
	MOVLW 0x63
DLOOP:	ADDLW -1
	BTFSS STATUS, 2
	GOTO DLOOP
	RETURN

Program 5(d) Coding

Question 6

- (a) Embedded software is directly linked to the electronic hardware.
- (i) Complete Table 6(a) truth table. (3 marks)
 - (ii) Draw a schematic diagram showing the interface between PIC16F877A microcontroller and a common cathode 7-segment display. (6 marks)
 - (iii) Write an assembly program to output the display letters continuously (LnOPqrStUY) one at a time, in sequence of L to Y as shown in Figure 6(a)(ii). Also, include comments for any instruction used. [Refer to Appendix for Instruction Set] (12 marks)

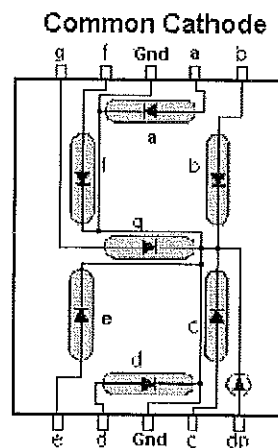

Figure 6(a)(i)

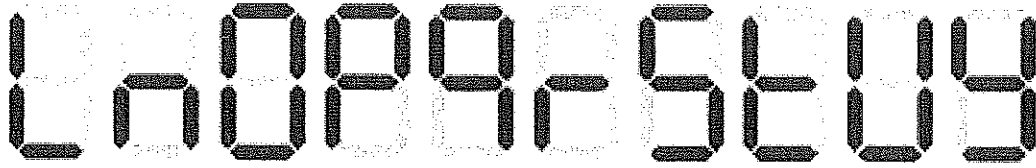

Figure 6(a)(ii)

dp	g	f	e	d	c	b	a	Hexa	Display
0	0	1	1	1	0	0	0	38	L
0	1	0	1	0	1	0	0	54	n
0	O
0	P
0	q
0	r
0	S
0	t
0	U
0	1	1	0	1	1	1	0	6E	Y

Table 6(a)

- (b) What is the main difference between an assembler directive and an assembly instruction? (4 marks)

- THE END -

EEE2114(F)/Apr16/Steven Khoo/02/05/16