

INTI
International College Penang

LAUREATE INTERNATIONAL UNIVERSITIES*

FINAL
Examination Paper

(COVER PAGE)

Session : August 2015

Programme : Diploma in Electrical and Electronic Engineering (DEEI)

Course : PHY1121: Physics

Date of Examination : 8th December 2015 (Tuesday)

Time : 8:00am – 10:00am Reading Time : Nil

Duration : 2 Hours

Special Instructions :

This paper consists of FIVE (5) questions. Answer any FOUR (4) questions in the answer booklet provided. All questions carry equal marks.

IMPORTANT NOTE : THIS PAPER SHOULD NOT BE TAKEN OUT OF THE EXAMINATION HALL

Materials permitted :

Non-Programmable Calculator

Materials provided :

Physics Formula Booklet

Examiner(s) :

Ms. Chong Mee Teng

Moderator :

Dr. Khoo Bee Ee

This paper consists of 6 printed pages, including the cover page.

INTI INTERNATIONAL COLLEGE PENANG

DIPLOMA IN ELECTRICAL AND ELECTRONIC ENGINEERING PROGRAMME
 PHY 1121: PHYSICS
 FINAL EXAMINATION: AUGUST 2015 SESSION

Instructions: This paper consists of **FIVE (5)** questions. Answer any **FOUR** questions in the answer booklet provided. All questions carry equal marks.

Question 1

- (a) Assume 1 year = 365.25 days.
- (i) How many nanoseconds are there in 1.00 year? (4 marks)
 - (ii) How many years are there in 1.00 second? (2 marks)
- (b) An object's position is given by $x = bt^3$, with x in meters, t in seconds, and $b = 1.5 \text{ ms}^{-3}$. Determine the:
- (i) instantaneous velocity and instantaneous acceleration at the end of 2.5 s, (4 marks)
 - (ii) average velocity and average acceleration during the first 2.5 s. (4 marks)
- (c) A hiker walks 2.50 km northward then 5.00 km southwest.
- (i) Sketch a vector diagram showing the graphical method in determining the total displacement vector D for the entire trip. (2 marks)
 - (ii) What are the magnitude and direction of the total displacement vector D ? (6 marks)
- (d) Use the dimensional analysis to check the validity of equation: $v = (2gh)^{\frac{1}{2}}$. (3 marks)

Question 2

- (a) A projectile is fired with speed of 51.2 ms^{-1} at 44.5° above the horizontal on a long flat firing range. Determine the:
- (i) maximum height reached by the projectile, (3 marks)
 - (ii) total horizontal distance covered, (3 marks)
 - (iii) velocity (magnitude and direction) of the projectile 1.50 s after firing. (5 marks)

- (b) A block of mass $m = 2 \text{ kg}$ moves along a horizontal frictional table under the action of forces shown in **Figure (1)**. The coefficient of kinetic friction between tabletop and block is $\mu_k = 0.20$.

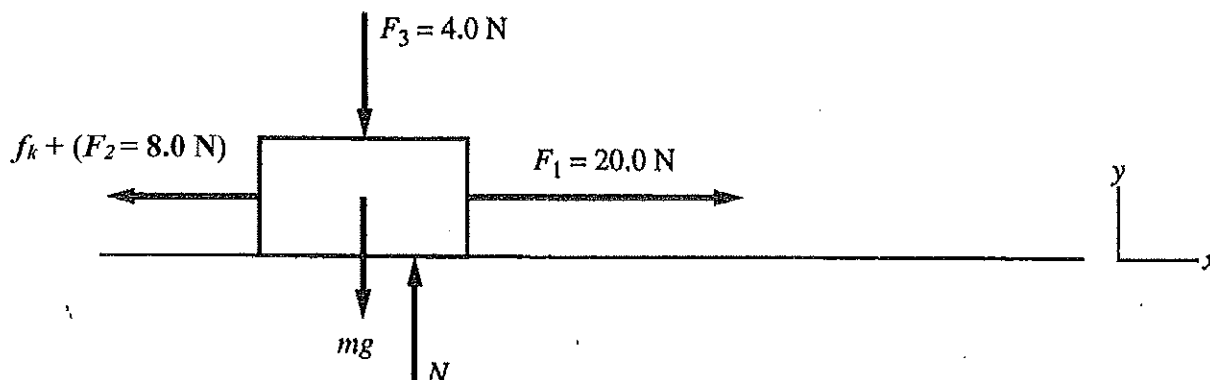

Figure (1)

- (i) Find the normal force due to the table. (2 marks)
 - (ii) Find the acceleration. (3 marks)
 - (iii) If the block starts from rest, how far will it move in 3.0 s? (2 marks)
- (c) In **Figure (2)**, the driver of a car (total mass 1200 kg) is breaking the speed limit by driving along a straight level motorway at 50 ms^{-1} in fog. The car runs into the back of a lorry (total mass 4000 kg) travelling at 10 ms^{-1} in the same direction as the car. The car becomes entangled in the lorry.

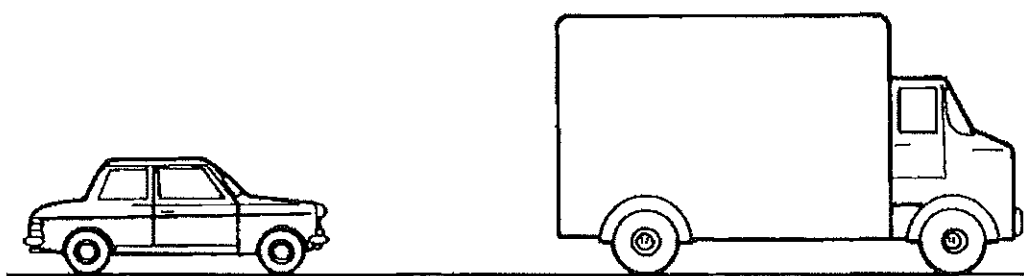

Figure (2)

- (i) Calculate the momentum of the car and the lorry just before the impact. (2 marks)
- (ii) Calculate the velocity of the combined wreckage just after the impact. (3 marks)
- (iii) Why will the back of the lorry be damaged less if the front of the car is designed to crumple on impact? (2 marks)

Question 3

- (a) In **Figure (3)**, a 2.5 kg block slides head on into a spring with a spring constant of 320.0 Nm^{-1} . When the block stops, it has compressed the spring by 7.5 cm. The coefficient of kinetic friction between the block and the horizontal surface is 0.25. While the block is in contact with the spring and being brought to rest,

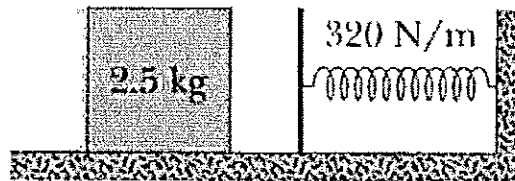

Figure (3)

- (i) What is the work done by the spring force? (2 marks)
- (ii) What is the increase in thermal energy of the block-floor system? (3 marks)
- (iii) What is the block's speed just as the block reaches the spring? (4 marks)
- (b) How many grams of ice at 0°C must one add to a 200 g cup of coffee at 90°C to cool it to 60°C ? Assume heat transfer with the surroundings to be negligible. (Given the latent heat of water, $L_F = 80 \text{ calg}^{-1}$, the specific heat of water, $c_w = \text{calg}^{-1}\text{C}^{-1}$) (4 marks)
- (c) The temperature of 0.15 mol of an ideal gas is held constant at 77°C while its volume is reduced to 25.0 % of its initial volume. The initial pressure of the gas is 1.25 atm. Determine the:
- (i) work done by the gas, (3 marks)
- (ii) change in its internal energy. (4 marks)
- (iii) Does the gas absorb or liberate heat? (1 mark)
- (d) **Figure (4)** shows two point charges, $Q_1 = +30 \mu\text{C}$ and $Q_2 = +50 \mu\text{C}$ are placed at 2.0 m apart. Find the location of a point where the electric field strength is zero. (4 marks)

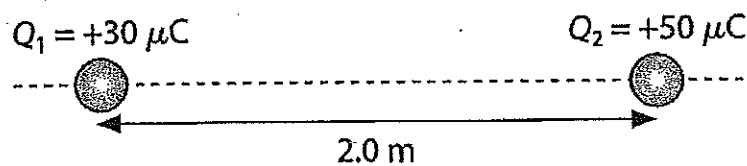
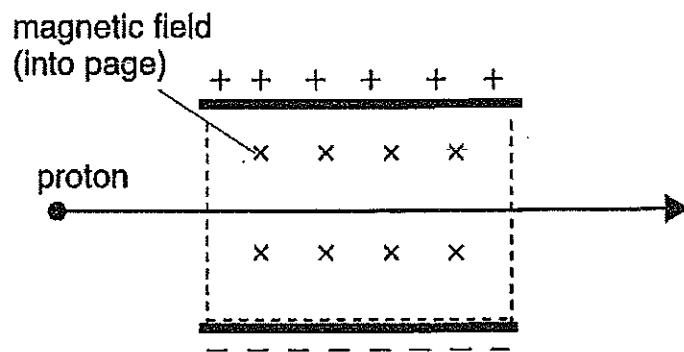

Figure (4)

Question 4

- (a) A quantity of ideal gas at $10.0\text{ }^{\circ}\text{C}$ and 100 kPa occupies a volume of 2.50 m^3 . (Given the universal gas constant, $R = 8.31\text{ Jmol}^{-1}\text{K}^{-1}$)
- Convert the 10.0°C to Kelvin scale and Fahrenheit scale respectively. (3 marks)
 - How many moles of the gas are present? (2 marks)
 - If the pressure is now raised to 300 kPa and the temperature is raised to $30.0\text{ }^{\circ}\text{C}$, how much volume does the gas occupy? Assume no leaks. (3 marks)
- (b) **Figure (5)** shows an electric field formed between two metal plates separated by 2.0 cm and a magnetic field of 0.025 T perpendicular to it. A proton travelling with a velocity of $3.0 \times 10^6\text{ ms}^{-1}$ enters the combined field perpendicularly and passes through undeflected by the fields.

**Figure (5)**

- Find the electric field strength between the two metal plates. (2 marks)
 - What is the voltage between the two plates? (2 marks)
 - Calculate the acceleration of the particle when the electric field is switched off. (4 marks)
 - Calculate the acceleration of the particle when the magnetic field is switched off. (4 marks)
- (c) A cylinder of diameter 1.00000 cm at $30.0\text{ }^{\circ}\text{C}$ is to be slid into a hole in a steel plate. The hole has a diameter of 0.99970 cm at $30.0\text{ }^{\circ}\text{C}$. To what temperature must the plate be heated? (Given $\alpha_{steel} = 1.1 \times 10^{-5}\text{ }^{\circ}\text{C}^{-1}$) (5 marks)

Question 5

(a) A current of 50.0 mA flows in a conductor.

- (i) How much charge passes through the conductor in 1 minute? (2 marks)
- (ii) Calculate the number of conduction electrons that pass through the conductor in 1.0 minute. (2 marks)

(b) **Figure (6)** shows a network of capacitors. A potential difference of 50 V is applied across *A* and *B*.

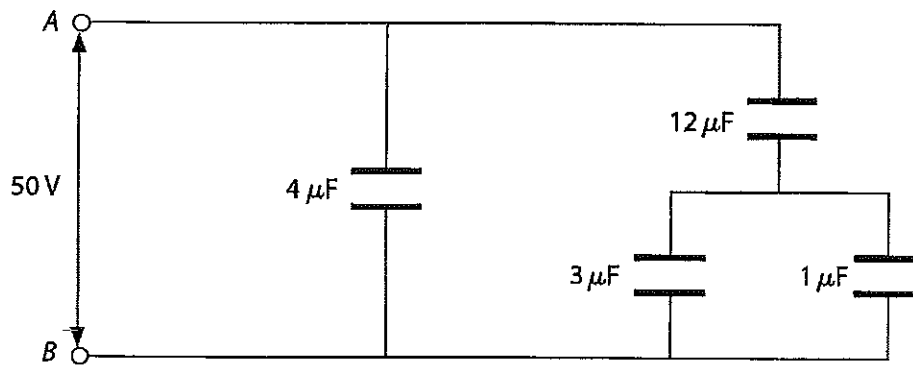

Figure (6)

- (i) Calculate the equivalent capacitance of the combination of capacitors. (4 marks)
- (ii) Calculate the charge on each capacitor. (6 marks)
- (c) A concave mirror with a radius of curvature of 50 cm forms an image of a real object which has been placed 30 cm from the mirror.
- (i) What is the focal length of the mirror? (2 marks)
- (ii) Calculate the distance of the image from the mirror. (2 marks)
- (iii) Define the magnification factor for this mirror. (2 marks)
- (d) The critical angle if a certain plastic in air is $\theta_c = 37.3^\circ$. What is the critical angle of the same plastic if it is immersed in water? (Given that the index of refraction for water, $n_{\text{water}} = 1.33$ and the index of refraction for air, $n_{\text{air}} = 1.0$) (5 marks)