



INTI
International College Penang

LAUREATE INTERNATIONAL UNIVERSITIES*

FINAL
Examination Paper

(COVER PAGE)

Session : August 2015

Programme : Diploma in Electrical and Electronic Engineering (DEEI)

Course : EEE2112: Introduction to Power Electronics & Drives

Date of Examination : 8th December 2015 (Tuesday)

Time : 2:00pm – 4:00pm Reading Time : Nil

Duration : 2 Hours

Special Instructions :

This paper consists of **SIX (6)** questions. Answer any **FOUR (4)** questions in the answer booklet provided. All questions carry equal marks.

IMPORTANT NOTE : THIS PAPER SHOULD NOT BE TAKEN OUT OF THE EXAMINATION HALL

Materials permitted :

Non Programmable Scientific Calculator

Materials provided :

Appendix

Examiner(s) : Mr. Liong Han Wen

Moderator : Dr. Ooi Beng Lee

This paper consists of 7 printed pages, including the cover page.

INTI INTERNATIONAL COLLEGE PENANG

DIPLOMA IN ELECTRICAL AND ELECTRONIC ENGINEERING PROGRAMME
 EEE 2112: INTRODUCTION TO POWER ELECTRONICS & DRIVES
 FINAL EXAMINATION: AUGUST 2015 SESSION

Instructions: This paper consists of **SIX (6)** questions. Answer any **FOUR (4)** questions in the answer booklet provided. All questions carry equal marks. The marks allocated to each sub-question are shown in brackets at the right-hand margin.

Question 1

- a. What is the minimum gate pulse width required to successfully turn ON a SCR in Figure Q1(a) if the latching current is 100mA. Assume that $V_1 = 5V$ and there is a 0.7V forward voltage drops across SCR and inductor initial current is 10mA. (6 marks)

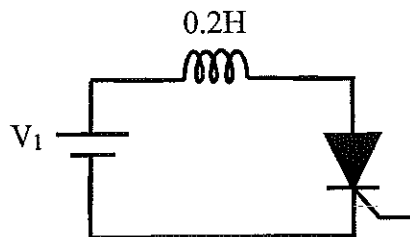

Figure Q1(a)

- b. A DC source (E) of 20V is supplying power to a 20Ω resistive load (R_L) through a switch as given in Figure Q1(b). Find the average power delivered to the load, if the switch is:
- Closed (2 marks)
 - Opened (2 marks)
 - Open 40% of the time (2 marks)
 - Close 20% of the time (2 marks)

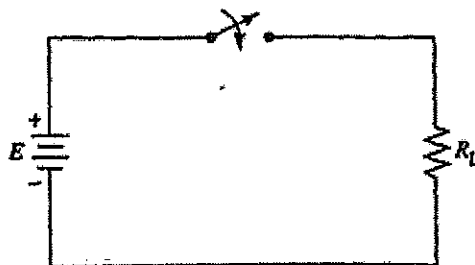

Figure Q1(b)

- c. For a SCR turn off circuit as shown in Figure Q1(c), given that $E = 300\text{V}$, $R = 20\Omega$, $C = 2.0\mu\text{F}$ and $V_C(0) = -200\text{V}$. Find the minimum time when the $V_{AK}(t_g)$ is negative value. (11 marks)

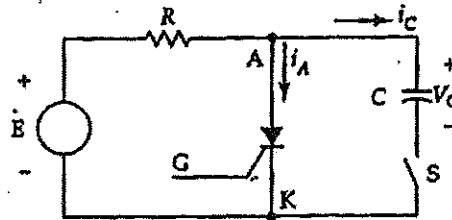

Figure Q1(c)

Question 2

- a. A circuit consisting of two diodes connected in series with current sharing resistors as shown in Figure Q2(a1) and Figure Q2(a2) shows the characteristics of the two diodes. The total reverse voltage is 4700V of which 60% of voltage appears across diode 1. Compute
- The reverse voltage for each diode and resistance value connected in parallel with each diode to limit the reverse voltage. (6 marks)
 - The total reverse current and the power consumed in the voltage sharing resistors. (3 marks)

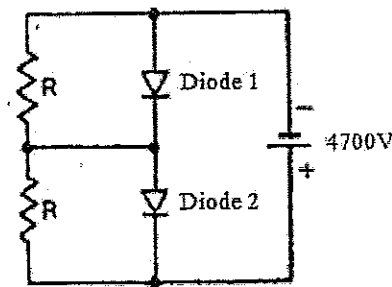

Figure Q2(a1)

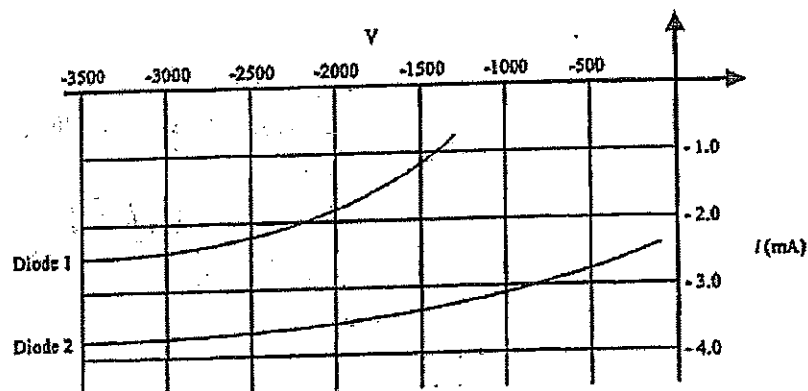

Figure Q2(a2)

- b. By referring to thyristor gate drive circuit in Figure Q1(c),
- What is the minimum V_{IN} that will fire the SCR, if the gate current needed to fire the SCR is 20mA. Assume that V_{GK} is 0.8V. (4 marks)
 - What is the power dissipated by the SCR if $R_L = 50\Omega$ with the E is connected to 10V. Assume that the SCR anode-cathode voltage when turn on is 1.2V. (5 marks)

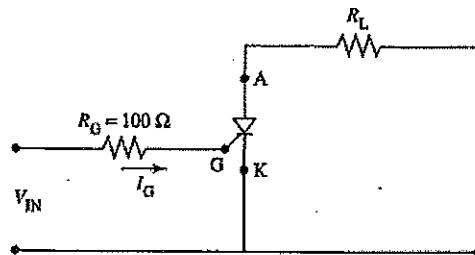

Figure Q1(c)

- c. A boost converter is to maintain a constant 50 V across a load resistor which may vary between 10-100 Ω . The input voltage varies between 20-40 V. Select the minimum value of inductance such that the converter just operates in the continuous conduction mode under all conditions. Assume switching frequency is 200kHz. (7 marks)

Question 3

- a. A full wave rectifier shown in Figure Q3(a) below uses a center taped transformer of turns ratio 1:2 with a freewheeling diode and supplies dc power to inductive load. The primary voltage, V_P is 120V_{RMS} sine wave and resistive portion of the load is 10 Ω . Assume that the inductance is very large. If the delay firing, α is 60°, find
- average load voltage (2 marks)
 - average load current (2 marks)
 - maximum load current (2 marks)
 - rms load current (2 marks)
 - average current in each SCR (3 marks)
 - power supplied to the load (3 marks)
 - average current in FWD (3 marks)

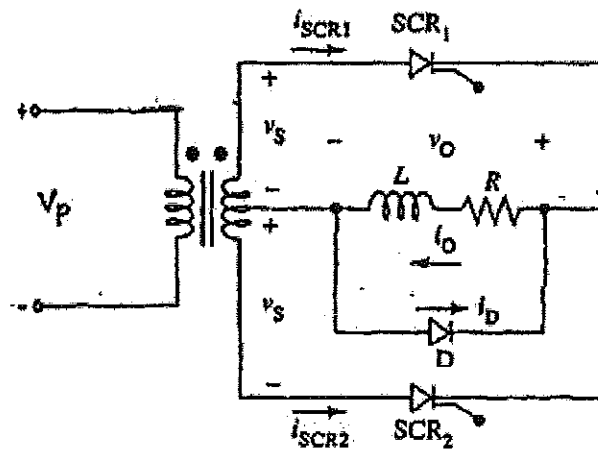

Figure Q3(a)

b. A single phase full wave bridge diode rectifier with resistive load 20Ω and a source voltage $240V_{RMS}$, $60Hz$. Find :

- i. Peak output current (2 marks)
- ii. Average load current (2 marks)
- iii. RMS load current (2 marks)
- iv. Power to the load (2 marks)

Question 4

a. A transistor bias as shown in Figure Q4(a) is switching at rate of $20kHz$. The rise time of the transistor is $1\mu s$ and the fall time is $2\mu s$. Find the total switching energy and power loss.

(10 marks)

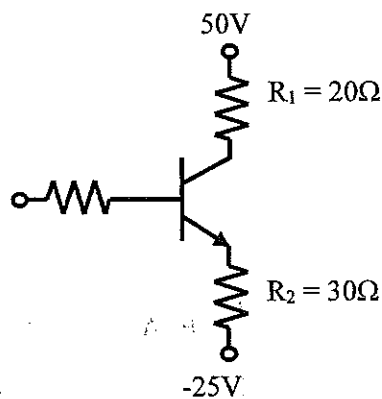

Figure Q4(a)

- b. For a circuit in Figure Q4(b1), $E = 5V$, $R = 0.2\Omega$ and the characteristic curve of the diode is shown in Figure Q4(b2). Assume that diode is a complete model, find the current I .

(5 marks)

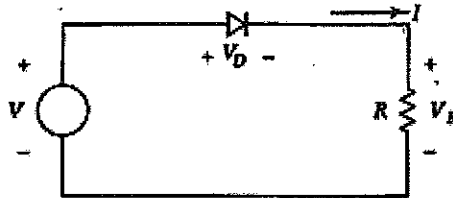

Figure Q4(b1)

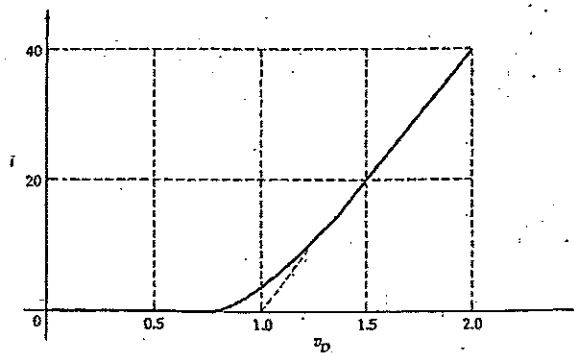

Figure Q4(b2)

- c. A half wave, phase controlled rectifier with resistive load has a load of 20Ω and a source voltage of $240V_{RMS}$, $60Hz$ sinusoid. The circuit operates with $\alpha = 20^\circ$.

Find:

- i. average load current (4 marks)
- ii. RMS load current (4 marks)
- iii. power to the load (2 marks)

Question 5

- a. A 3-phase SCR rectifier is supplied by a line voltage $480V_{(line)RMS}$ $60Hz$ sinusoid source.

The load is a 25Ω resistance. The circuit operates with $\alpha = 10^\circ$. Find:

- i. Average load current (4 marks)
- ii. Peak diode current (2 marks)
- iii. Average diode current (3 marks)

- b. Repeat part a)i. if the α is changed to 70° . (5 marks)

- c. State two methods to turn off SCR. (2 marks)

- d. An SCR is used as power switch to control power deliver to the load R as shown in Figure Q5(d). A RC snubber circuit is connected parallel to the SCR for power device protection purpose. The maximum allowable dV_c/dt allowed is $200V/\mu s$. Assume that the capacitor

initial voltage equal to zero when charging. Assume $V_s = 230V_{RMS}$

- i. What will be the minimum value of C_s ? (6 marks)
- ii. Initial discharge of C should be limited to 4A at SCR turn on. Find the maximum value of R_s . (3 marks)

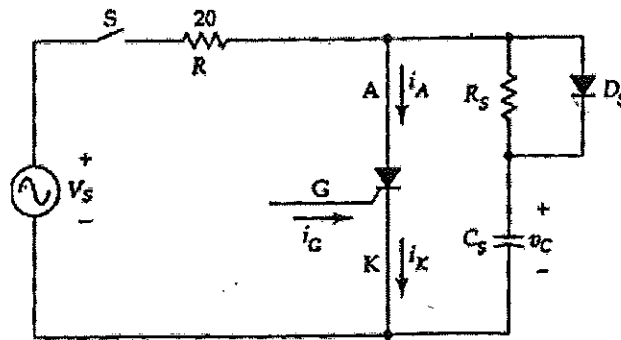

Figure Q5(d)

Question 6

- a. The boost converter in Figure Q6(a) is used to produce an average output voltage of 480V from a constant dc source $E=120V$. The output power from the converter is 1000W. Assuming the switch operates at 20kHz, inductance of the converter is 20% larger than the minimum value and output voltage ripple of 1% of the average output voltage. Find:
 - i. Duty cycle D , T_{ON} and T_{OFF} (6 marks)
 - ii. Resistance R_L (2 marks)
 - iii. Inductance L (3 marks)
 - iv. Capacitance C (3 marks)
 - v. $I_{L(min)}$ (3 marks)
 - vi. Minimum voltage and current ratings of the switch (6 marks)

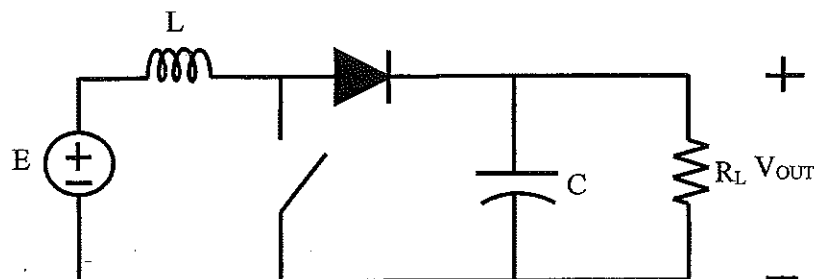

Figure Q6(a)

- b. What are the two regions in BJT output characteristics curve that are used for switching purpose? (2 marks)

--THE END--

Appendix : Trigonometry Identities

Sum or difference of two angles:

$$\sin(a \pm b) = \sin a \cos b \pm \cos a \sin b$$

$$\cos(a \pm b) = \cos a \cos b \mp \sin a \sin b$$

$$\tan(a \pm b) = \frac{\tan a \pm \tan b}{1 \mp \tan a \tan b}$$

Double angle formulas:

$$\sin 2\theta = 2 \sin \theta \cos \theta$$

$$\cos 2\theta = 1 - 2 \sin^2 \theta$$

$$\tan 2\theta = \frac{2 \tan \theta}{1 - \tan^2 \theta}$$

$$\cos 2\theta = 2 \cos^2 \theta - 1$$

$$\cos 2\theta = \cos^2 \theta - \sin^2 \theta$$

Pythagorean Identities:

$$\tan^2 \theta + 1 = \sec^2 \theta$$

$$\sin^2 \theta + \cos^2 \theta = 1$$

$$\cot^2 \theta + 1 = \csc^2 \theta$$

Half angle formulas:

$$\sin^2 \theta = \frac{1}{2}(1 - \cos 2\theta)$$

$$\cos^2 \theta = \frac{1}{2}(1 + \cos 2\theta)$$

$$\sin \frac{\theta}{2} = \pm \sqrt{\frac{1 - \cos \theta}{2}}$$

$$\cos \frac{\theta}{2} = \pm \sqrt{\frac{1 + \cos \theta}{2}}$$

$$\tan \frac{\theta}{2} = \pm \sqrt{\frac{1 - \cos \theta}{1 + \cos \theta}} = \frac{\sin \theta}{1 + \cos \theta} = \frac{1 - \cos \theta}{\sin \theta}$$