

INTI

INTERNATIONAL COLLEGE PENANG (5072 32-U)
LAUREATE INTERNATIONAL UNIVERSITIES

FINAL
Examination Paper
(COVER PAGE)

INTI LIBRARY
INTI INTERNATIONAL COLLEGE PENANG

Session : AUGUST 2012

Programme : DIPLOMA IN ELECTRICAL AND ELECTRONIC ENGINEERING

Course : EEE 2106 ELECTRICAL POWER SYSTEM

Date of Examination : 13 December 2012

Time : 11A.M. – 1P.M. Reading Time : Nil

Duration : 2 Hours

Special Instructions :

This paper consists of SIX (6) questions. Answer any FOUR (4) questions in the answer booklet provided. All questions carry equal marks.

Materials permitted :

Non-Programmable Scientific Calculator

Materials provided :

Nil

Examiner(s) : KEN KONG SENG KUOK

Moderator : CHAN TSE WEI

This paper consists of 5 printed pages, including the cover page.

INTI INTERNATIONAL COLLEGE PENANG

DIPLOMA IN ELECTRICAL AND ELECTRONIC ENGINEERING PROGRAMME (DEE/I)

EEE 2106: ELECTRICAL POWER SYSTEM
FINAL EXAMINATION: AUG2012 SESSION

Instructions: This paper consists of SIX (6) questions. Answer any FOUR (4) questions in the answer booklet provided. All questions carry equal marks.

Question 1

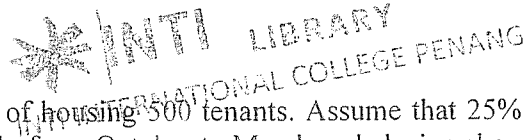

- (a) Consider a new shopping complex capable of housing 500 tenants. Assume that 25% of the tenants are seasonal, operating actively from October to March and closing shop 50% for the remaining time in the year. The remaining tenants will be operating steadily throughout the year. Each tenant on the average will install 4 power points, drawing 0.2 A of current each, and 9 lighting points consuming at most 405 W. The regular business hour is from 11 a.m. to 11 p.m. The central cooling system is operating at 1 MW during the business hour and shut down for the rest of the day. General lighting in the building is consuming 12.5 kW during the business hour. Busiest shopping seasons are January, February, August and December. During these periods of the year, the general power consumption of the building will increase by 20%.
- (i) Plot the yearly load curve according to the information provided. (11 marks)
(Use average value for each month)
 - (ii) Find the maximum demand and load factor from the load curve constructed in part (i). (3 marks)
 - (iii) The distribution substation nearby is supplying 1.6 MVA during busiest months during business hour. Calculate the reactive power consumption in the shopping complex. (3 marks)
- (b) Consider the following diagram.

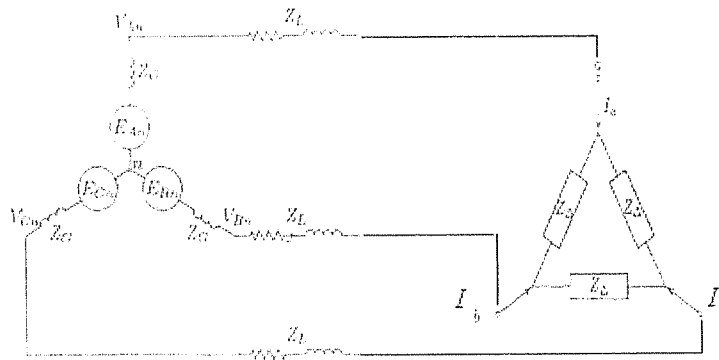

Figure 1(b): Three phase connection

Given the phase-to-neutral voltage supply is 230 V. The generator impedance is 0.012Ω . The line impedance is $0.01 + 0.25j \Omega$. The load impedance, Z_{Δ} , is $100 + 20j \Omega$.

- (i) Draw a per phase diagram for the figure. (3 marks)
- (ii) Find the value of the current, I_a , I_b and I_c , feeding into the delta ring. (5 marks)

Question 2

- (a) Describe the operational principles of the following wave energy converter along with suitable diagram and example.
- (i) Attenuator (5 marks)
 - (ii) Point absorber (5 marks)
 - (iii) Surge converter (5 marks)
- (b) During non monsoon season, the average wind speed in east coast of Malaysia is 30 km/h. During the monsoon season, the average wind speed would surpass 100 km/h. The cheapest available wind generator in these regions is of the type that can produce 10 kW at rated speed of 400 r.p.m. and has a tip speed ratio (T.S.R.) of 5. The blades are 3 m in length. If the energy supplying body is to use these wind generators to satisfy the demand of 10,000 household along the coastal region with the average demand of 2 kW per household, how many wind generators are sufficient to provide for an all year round demand of these households? Assume 80% load factor. The air density is 1.201 kg/m^3 . Assuming the output capacity of the generators is in direct proportion to the wind speed and the cut-in wind speed is 5 m/s. (10 marks)

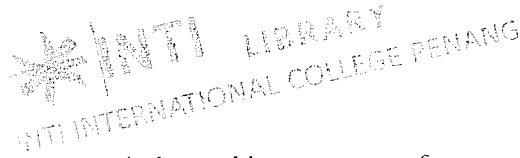

Question 3

- (a) A 50 Hz, 3-phase transmission line has the following constants:
 $R = 10 \Omega/\text{phase}$; inductive reactance = $20 \Omega/\text{phase}$; capacitive susceptance = $4 \times 10^{-4} \text{ mho}/\text{phase}$.
 Calculate the following when the line is supplying a balanced load of 10,000 kW at 66 kV, 0.8 p.f. lagging, using nominal T method:
- (i) Sending end voltage (5 marks)
 - (ii) Line current (4 marks)
 - (iii) Sending end power factor and transmission efficiency (4 marks)
- (b) A single core cable of 0.5 km long has a core diameter of 0.5 cm and diameter under sheath of 2 cm. The relative permittivity of insulating material is 3.2. The supply voltage is 11 kV, 50 Hz. Take specific resistance of insulation as $5 \times 10^{12} \Omega/\text{m}$, calculate the following:
- (i) The capacitance of the cable, with $\epsilon_0 = 8.845 \times 10^{-12} \text{ Fm}^{-1}$ (3 marks)
 - (ii) The insulation resistance (3 marks)
 - (iii) The charging current per conductor (3 marks)
 - (iv) The dielectric loss (3 marks)

Question 4

- (a) Describe two voltage control methods involving static capacitors and transformers respectively. (10 marks)
- (b) A 3-phase load of 10 MW at 0.8 p.f. lagging is supplied at 33 kV by an overhead line, each conductor of which has a resistance of 2.9Ω and an inductive reactance of 6.5Ω . A three-phase bank of capacitors is connected to the load end of the line so that the voltage at the sending end is equal to that at the load. Calculate the kVAr rating of the capacitors. (15 marks)

Question 5

- (a) The variable operating cost of three generating units are given by
- $$F_1 = 350 + 7.20P_1 + 0.0040P_1^2 \quad \text{RM/hr}$$
- $$F_2 = 500 + 7.30P_2 + 0.0025P_2^2 \quad \text{RM/hr}$$
- $$F_3 = 600 + 6.74P_3 + 0.0030P_3^2 \quad \text{RM/hr}$$
- where P_1 , P_2 and P_3 are in MW. The governors are set such that generators share the load equally. Neglecting line losses and generator limits, find the total cost in RM/hr for the following cases
- (i) Case 1: Total demand, $P_D = 450$ MW (2 marks)
- (ii) Case 2: Total demand, $P_D = 745$ MW (2 marks)
- (iii) Case 3: Total demand, $P_D = 1335$ MW (2 marks)
- (b) The generating units in question (a) have generating limits (in MW) as follow:
- $$122 \leq P_1 \leq 400$$
- $$260 \leq P_2 \leq 600$$
- $$50 \leq P_3 \leq 445$$
- (i) Neglecting line losses, determine the optimal scheduling of generation for each loading as in question (a) using analytical method. (14 marks)
- (ii) Find the savings in RM/hr for each case compared to the costs in question (a). (5 marks)

Question 6

A simple three-bus power system single line diagram is shown in the following Figure Q6. All impedances are expressed in per unit on a common 50 MVA base, with the resistances conveniently neglected. All generators are running at their rated voltage, or 1 p.u., and rated frequency with their e.m.f.s in phase.

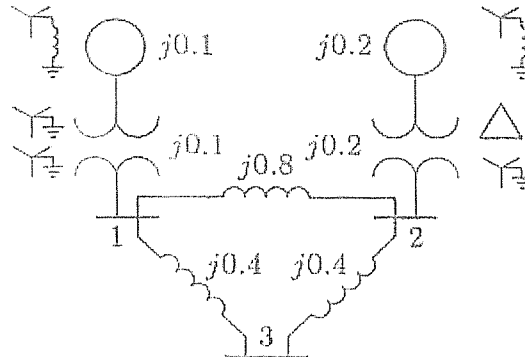

Figure Q6

If a balanced three-phase fault with a fault impedance $Z_f = 0.16$ p.u. occur on Bus 2, find the following in p.u.:

- Equivalent impedance of the power system in fault condition (8 marks)
- The fault current flowing through Bus 2, assuming all pre-fault bus voltages are equal to 1.0 p.u. (2 marks)
- The bus voltages on all three bus after fault (9 marks)
- The short-circuit current in all the lines connecting the buses (6 marks)

--THE END--

EEE2106 (F) Aug2012/Ken Kong/181012

INTI LIBRARY
INTI INTERNATIONAL COLLEGE PENANG