

**FINAL ALTERNATIVE ASSESSMENT
Take-Home**

(COVER PAGE)

Session : August 2020

Programme : Diploma In Information Technology (DITN)

Course : ICT2101: Computer Organisation

Date of Examination :

Time Start : December 18, 2020 (Friday) @ 8.00am

Time End : December 18, 2020 (Friday) @ 2.00 pm

Duration : 6 Hours

Special Instructions :

Section A: This section consists of **THREE (3)** questions. Answer **ALL** questions.

Section B: This section consists of **THREE (3)** questions. Answer **ALL** questions.

Materials permitted : Nil

Materials provided : Nil

Examiner(s) : Ryan Tee Ah Ann and Kavitha Thamadharan

Chief Moderator : Ang Chee Huei

This paper consists of 8 printed pages, including the cover page

DIPLOMA IN INFORMATION TECHNOLOGY PROGRAMME (DITN)
 ICT2101: COMPUTER ORGANIZATION
 FINAL ALTERNATIVE ASSESSMENT: AUGUST 2020 SESSION
 (SIX (6) HOURS TAKE-HOME ASSIGNMENT)

COURSEWORK SPECIFICATION COVER SHEET

Subject Code : ICT2101
Subject Description : Computer Organization
Programme : DITN
Section : Y1
Lecturer : Ryan Tee
Coursework Description : Individual Assignment
 (Take-Home)

Name:

ID:

Declaration: I / ~~We~~ declare that this Coursework is my / ~~our~~ own work. Cheating is a serious academic offence. I / ~~we~~ agree that I / ~~we~~ have read the College guidance on Academic Honesty.

Signature(s) _____

Course Learning Outcomes:

Upon completing this course, the students will be able to:

CLO1: Describe the architecture of N-bit microprocessor and the corresponding memory and I/O subsystem design. [C2, PLO1]

CLO2: Display the ability to apply basic assembly language in relation to microprocessor instruction set and addressing [P3, PLO3]

CLO3: Analyze the concept of memory organization, I/O organization, CISC vs RISC architecture of a computer system in relation to CPU functions and performance [C4, PLO2]

ASSESSMENT CRITERIA		TOTAL MARKS	GIVEN MARKS
Section A: (40 Marks)	Q1	12	
	Q2	12	
	Q3	16	

Section B: (60 Marks)	Q1	16	
	Q2	7	
	Q3	37	
Sub-Total		100%	
Penalty for Late Submission/Plagiarism			
TOTAL FINAL MARKS GIVEN (40%)			

TO BE COMPLETED BY LECTURER	
GRADE / MARK AWARDED	COMMENTS:

(ONLY ATTACH THE ABOVE MARKING GUIDE AS COVER PAGE)

ALTERNATIVE ASSESSMENT AUGUST 2020
Specification

Report's Requirements:

1. You are required to write a report of **not exceeded 2500 words** (which does not include cover page, table of contents, citation/references and supporting documents) in Times New Roman/Arial, 12 points font, justify align and 1.5 lines spacing.
2. It is an advantage if you can find some *empirical materials*, pictures/diagrams as support and reference.
3. Details to include in the report Header:
 - i. Should be capitalized, bold and left-aligned.
 - ii. Subject Code and Subject Title.
4. Details to include in the report Footer:
 - i. Should be capitalized, bold.
 - ii. Prepared by (student name)
 - iii. Page #
5. Your answers for both Section **A** and **B**, which include the mathematics calculation, **MUST BE TYPED** using **Microsoft Words** and **DO NOT** write back the questions.
6. Your answers should adopt the format of an academic piece of report work. Write in fluent, formal English.

7. **PENALTY**

(A) Plagiarism

Plagiarism rule shall apply.

The guideline for plagiarism is as follows:

0 – 25% of plagiarised material: no deduction of marks

26 – 50% of plagiarised material: 30% deduction of marks

51 – 80% of plagiarised material: 50% deduction of marks

81 and more: 0 mark awarded and student will receive a failed grade for the paper

(B) Late Submission

Submission after the deadline will be subjected to the following penalty:

1. Within one hour after the deadline: 50% deductions of the awarded marks.
2. More than one hour after the deadline: Zero marks

Please take notes: You are **ONLY** allow to submit the assignment in **ONE (1) attempt**. You must name your file/report with **the module code and your student ID** to blackboard under **Final Alternative Assessment AUGUST 2020** folder.

For example, **ICT2101_J19xxxxxx** (as your file name)

Compile the Cover page (marking guide ONLY), Table of Contents, The main body of your typed assignment/answers, Citations/references in ONE (1) file.

For the main body of the assignment, **DO NOT** copy the questions to avoid the high % of plagiarism on Safe Assign. Your answers should be arranged in sequence (e.g. Section A (Q1, Q2, Q3) and Section B (Q1, Q2, Q3) and labelled properly.

- 8.** Any source taken from books, websites etc. HAS TO BE CITED with referencing (e.g. Harvard Referencing). **(DO NOT USED LECTURE NOTES AND SLIDES as references)**. DO NOT COPY AND PASTE and shares with your friends but write in your own understanding and paraphrase.

**DIPLOMA IN INFORMATION TECHNOLOGY PROGRAMME (DITN)
ICT2101: COMPUTER ORGANISATION
FINAL ALTERNATIVE ASSESSMENT: AUGUST 2020 SESSION
(SIX (6) HOURS TAKE HOME ASSIGNMENT)**

SECTION A: (40 marks)

Instruction: This section consists of **THREE (3)** questions. Answer **ALL** questions.

Question 1

Answer the following questions. Show all your workings.

- (i) Write down your actual/real student registration ID. Convert the last two decimal digits of your student registration ID into equivalent Binary Coded Decimal code. (4 marks)
- (ii) Solve the arithmetic operation $1000\ 1011_2 - 227_{10}$ in binary using 2's complement method. Give your final answer in binary. (8 marks)

Question 2

Identify and explain the **THREE (3)** data transfer modes between I/O peripherals and main memory. (12 marks)

Question 3

Figure 1 shows the diagram of an addressing mode X.

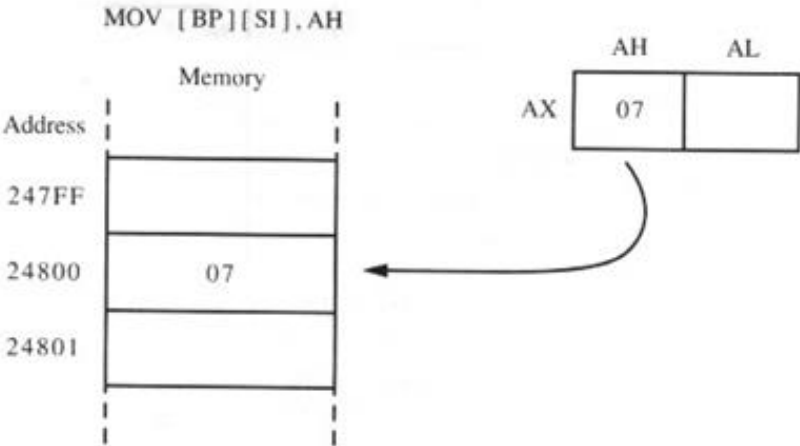

Figure 1

- (i) Identify the addressing mode X. (2 marks)

- (ii) Show **TWO (2)** examples of ASM instruction that use the addressing mode above. (4 marks)
- (iii) Briefly explain **TWO (2)** other types of addressing modes with example. (10 marks)
- (Total: 40 marks)**

SECTION B (60 marks)

Instructions: This section consists of **THREE (3)** questions. Answer **ALL** questions.

Question 1

- (a) Cache is a type of memory situated between the processor and the main memory in the memory hierarchy. It is also used to refer to any storage managed to take advantage of locality of access. Briefly explain the following terms commonly used for cache memories:
- (i) Tag
 - (ii) Valid bit
 - (iii) Cache hit
 - (iv) Cache miss
 - (v) Hit rate
 - (vi) Miss rate
- (12 marks)
- (b) It is usually difficult or impossible to figure out what data will be “most frequently accessed” before a program actually runs, which makes it hard to know what to store into the cache memory. In practice, most programs exhibit locality, which the cache can take advantage of. Explain the terms temporal and spatial locality with examples. (4 marks)

Question 2

Using an appropriate diagram(s), show how major components of a basic microprocessor system are connected through different type of buses. Briefly describe the functions of these buses.

(7 marks)

Question 3 (CASE)

The pipeline design of CPU allows storing and executing instructions in an orderly process. It is a technique used that allows multiple instructions to be overlapped during execution.

a) With the appropriate diagram(s), you are required to write about the working principles of pipelining, which includes the design of pipeline, the stages involved and the pipeline hazards.

(27 marks)

b) Besides pipelining, suggest and discuss **ONE (1)** other way you think can increase the CPU performance especially in multitasking and multiusers environment.

(10 marks)

(Total: 60 marks)

≈ **The End** ≈

Formatted/ICT2101(Aug2020)final/hizam