

## INTI INTERNATIONAL UNIVERSITY

## FOUNDATION PROGRAMME (ENGINEERING/SCIENCE) (CFSI)

EGR 1203: ENGINEERING MECHANICS  
FINAL EXAMINATION: AUGUST 2015 SESSION

**Instructions:** This paper consists of **FIVE (5)** questions. Answer any **FOUR (4)** questions in the paper provided. All questions carry equal marks.

**Question 1**

(a) Evaluate each of the following to three significant figures and express each answer in SI units using an appropriate prefix:

i)  $(0.005 \text{ mm})^2$

(1 mark)

ii)  $0.631 \text{ Mm} / (8.60 \text{ kg})^2$

(2 marks)

(b) Refer to Figure Q1-(b), if  $F_1 = 600 \text{ N}$  and  $\phi = 30^\circ$ , determine the magnitude of the resultant force acting on the eyebolt and its direction measured clockwise from the positive  $x$  axis.

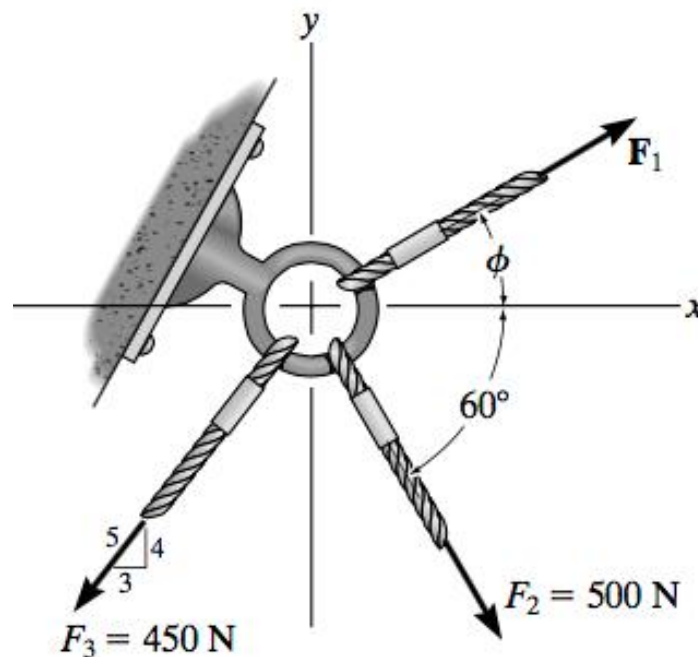

Figure Q1-(b)

(4 marks)

(c) The mast or pole is subjected to the three forces shown as in Figure Q1-(c).

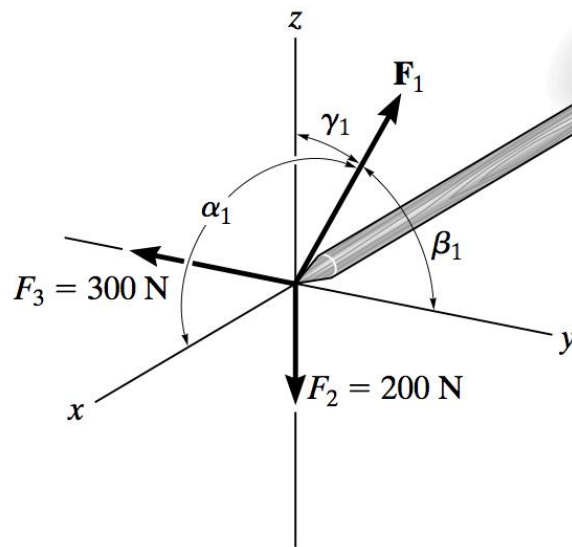

Figure Q1-(c)

- i) Express the vector force  $\mathbf{F}_1$  into Cartesian Vector format in terms of  $\alpha_1, \beta_1, \gamma_1$  (2 marks)
- ii) Determine the coordinate direction angles  $\alpha_1, \beta_1, \gamma_1$  of  $\mathbf{F}_1$  so that the resultant force acting on the mast is  $F_R = \{350 \mathbf{i}\} \text{ N}$  (3 marks)

- (d) Determine the force vector  $F_{AB}$  in Cartesian vector form as shown in Figure Q1-(d).

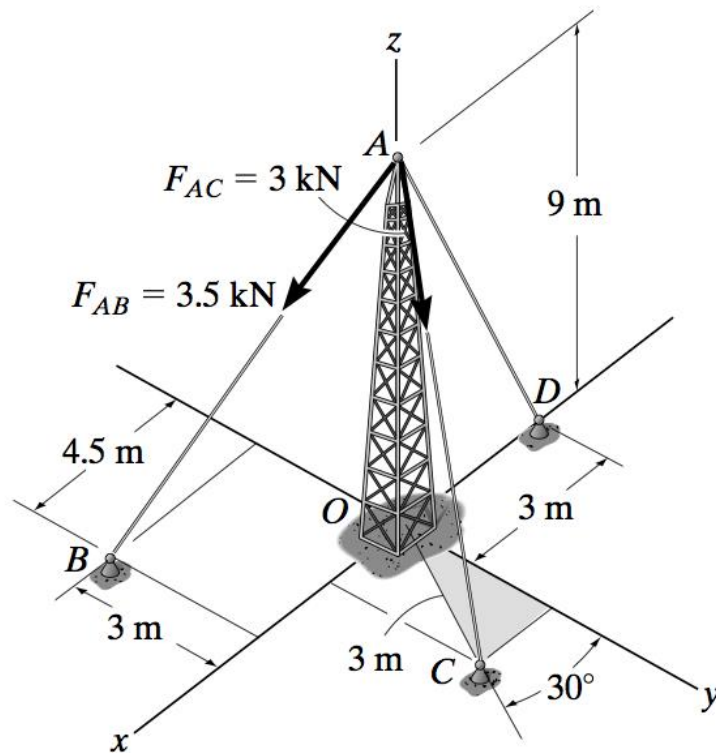

Figure Q1-(d).

(5 marks)

- (e) The members of a truss in Figure Q1-(e) are connected to the gusset plate. If the forces are concurrent at point O, determine the magnitudes of F and T for equilibrium when the angle  $\theta = 30^\circ$

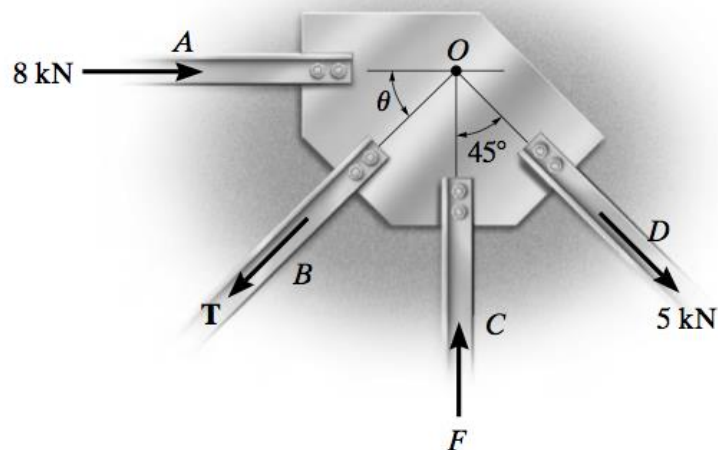

Figure Q1-(e)

(4 marks)

- (f) Two men exert forces of  $P = 250 \text{ N}$  and  $F = 400 \text{ N}$  on the ropes as shown in Figure Q1-(f). Determine the moment of each force about A and justify if the pole will rotate, clockwise or counterclockwise.

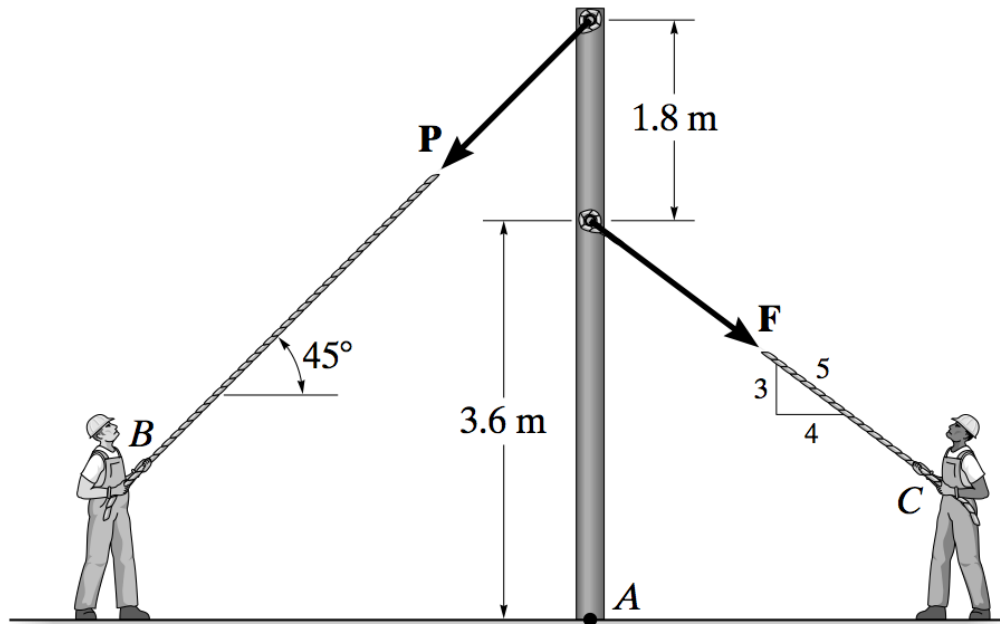

Figure Q1-(f)

(4 marks)

### Question 2

(a) Following questions are based on Figure Q2-(a).

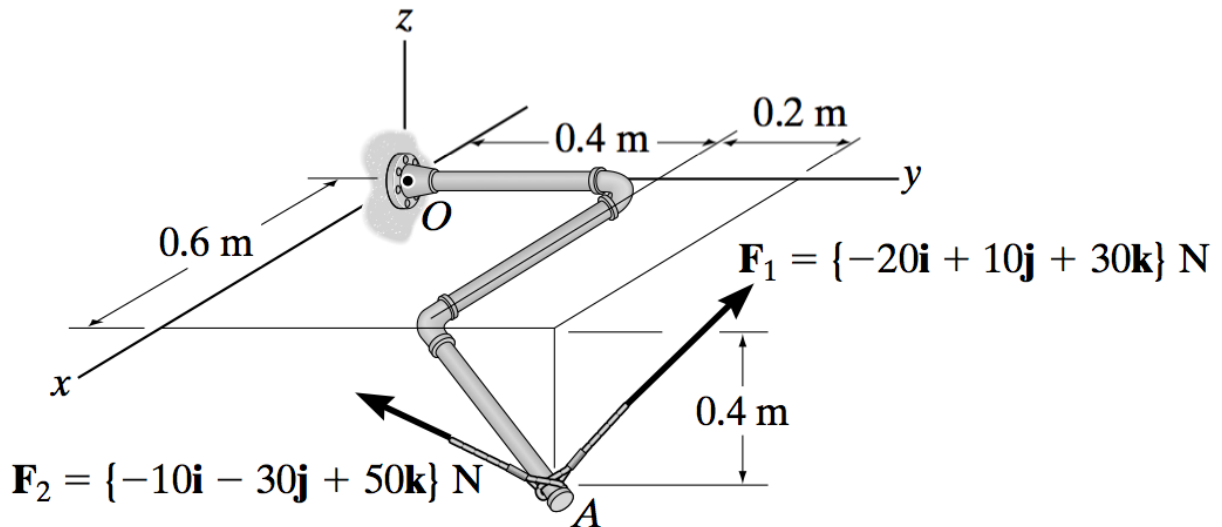

Figure Q2-(a)

i) Determine the position vector  $\mathbf{r}_{OA}$ .

(2 marks)

ii) Determine the resultant moment produced by the two forces about point  $O$  and express the result in Cartesian vector.

(4 marks)

(b) Calculate the resultant couple moment acting on the beam about point  $O$  in Figure Q2-(b).

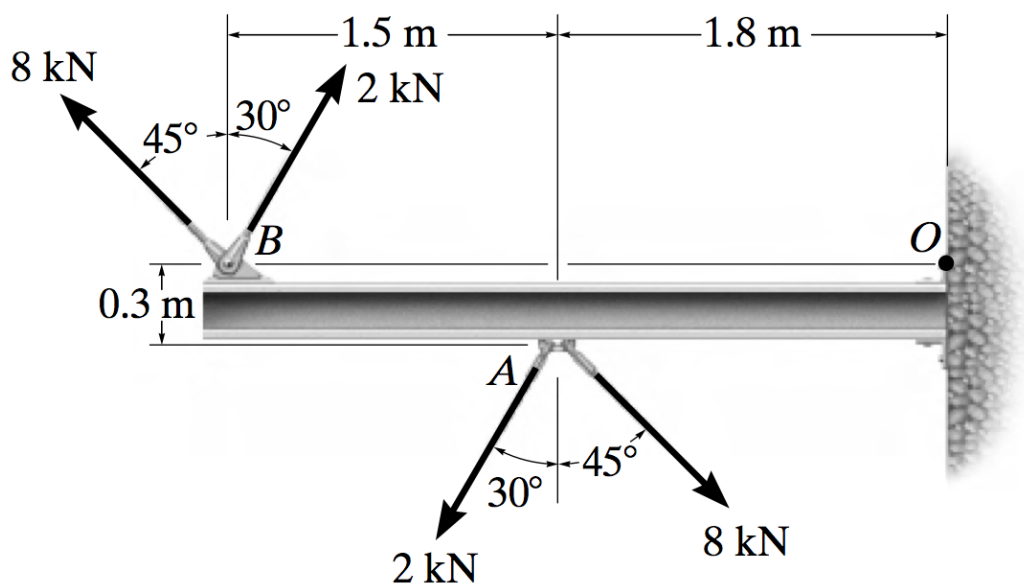

Figure Q2-(b)

(4 marks)

- (c) Replace the force system in Figure Q2- (c) acting on the post by a resultant force as measured from point A.

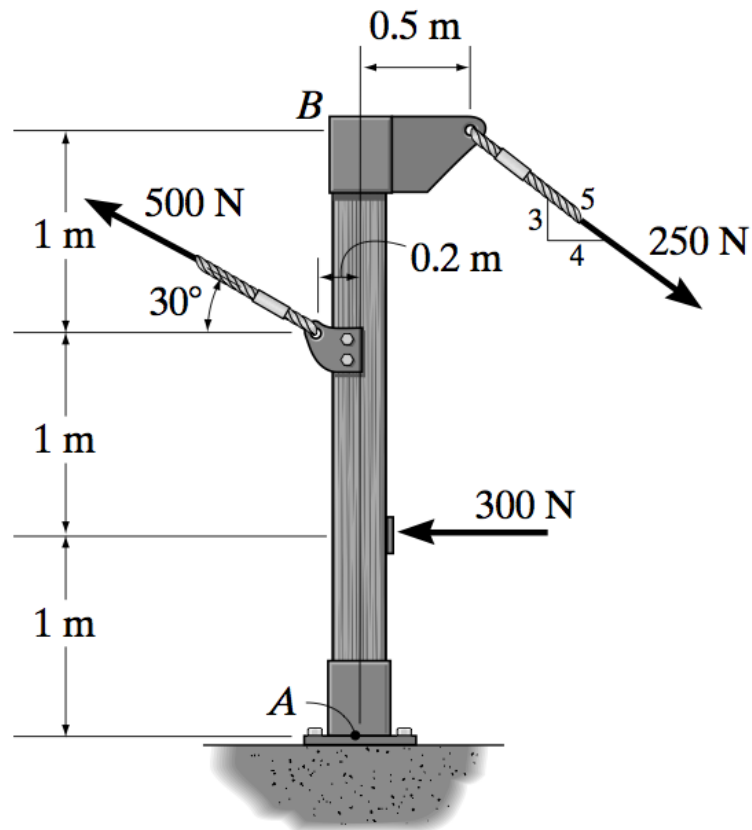

Figure Q2-(c)

- i) Calculate the total horizontal force and its direction. (2 marks)
- ii) Calculate the total vertical component force and its direction. (2 marks)
- iii) Determine the magnitude and direction of the resultant force. (3 marks)

- (d) Draw the free-body diagram of the beam in Figure Q2-(d) which supports the 80-kg load and is supported by the pin at A and a cable which wraps around the pulley at D.

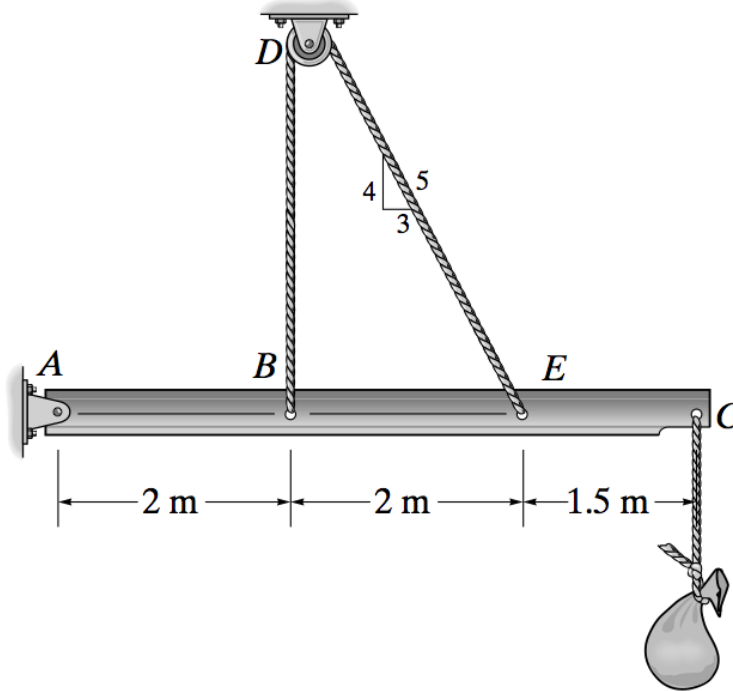

Figure Q2-(d)

(2 marks)

- (e) A skeletal diagram of a hand holding a load is shown in Figure Q2-(e). If the load and the forearm have masses of 2 kg and 1.2 kg, respectively, and their centers of mass are located at  $G_1$  and  $G_2$ , determine

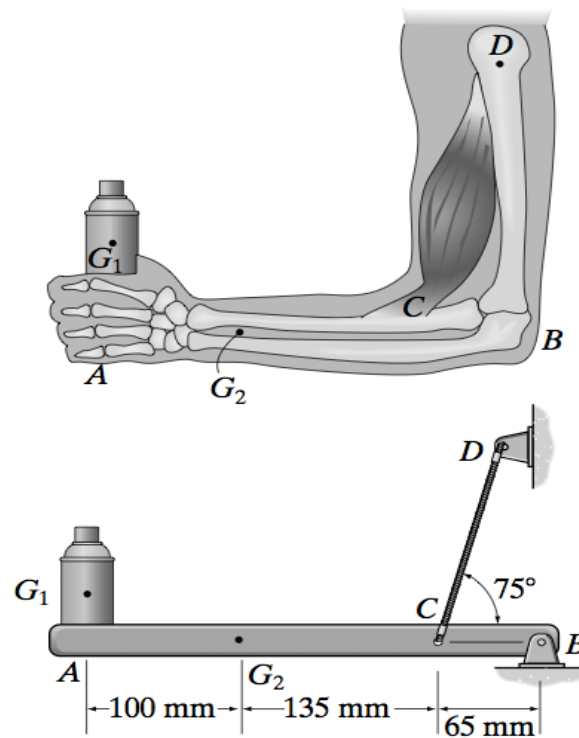

Figure Q2-(e)

- i) the force developed in the biceps CD at the elbow joint B, (2 marks)
- ii) the horizontal and vertical components of reaction at the elbow joint B. (4 marks)

### Question 3

- (a) The truss in Figure Q3-(a) is used to support a balcony is subjected to the loading as shown. Considered each joints a pin joint given that  $P_1 = 3 \text{ kN}$  while  $P_2 = 2 \text{ kN}$ . Determine the force in each member and state whether the members are in tension or compression for following:

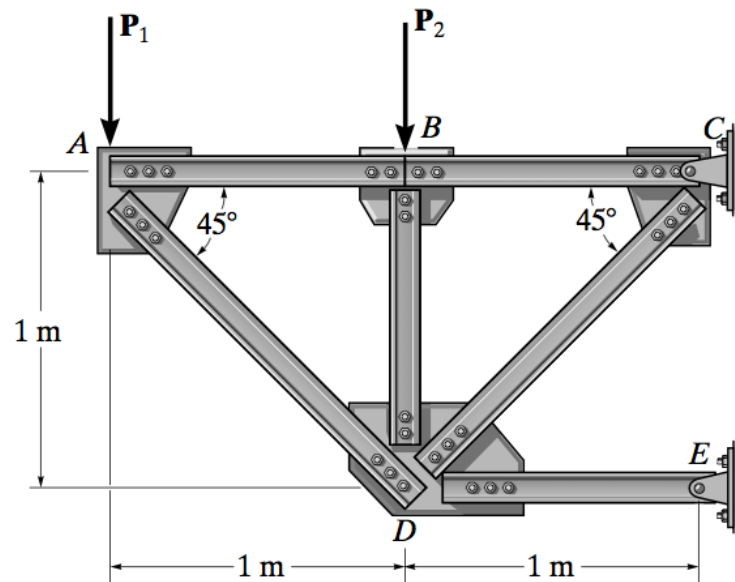

Figure Q3-(a)

- i) Member truss AD and AB,

(4 marks)

- ii) Member truss BD and BC,

(4 marks)

- (b) The following questions are based on Figure Q3-(b). Coefficients of friction are  $\mu_s = 0.40$  and  $\mu_k = 0.30$  between all surfaces of contact.

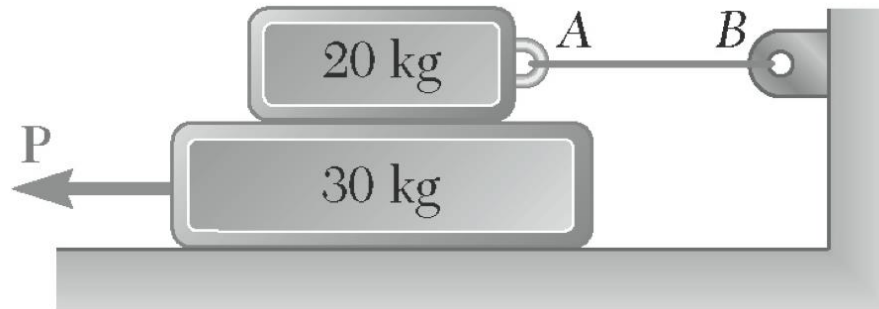

Figure Q3-(b)

- i) Calculate the tension of the cable AB developed. (2 marks)
  - ii) Determine the normal force exerted at the 30 kg block. (3 marks)
  - iii) Determine the smallest force **P** required to start the movement of 30 kg block. (2 marks)
- (c) Locate the centroid  $\bar{x}$  of the area of the shaded area in Figure Q3-(b).

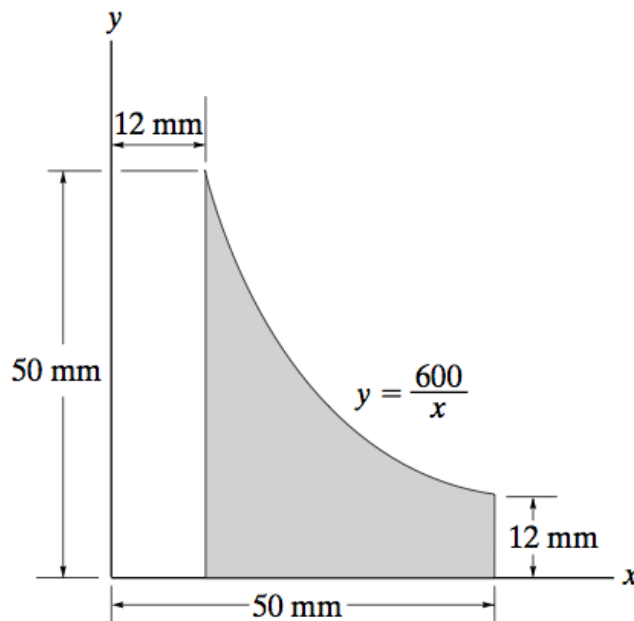

Figure Q3-(c)

(5 marks)

- (d) Determine the moment of inertia of the beam's cross-sectional area about the  $y$  axis in Figure Q3-(c).

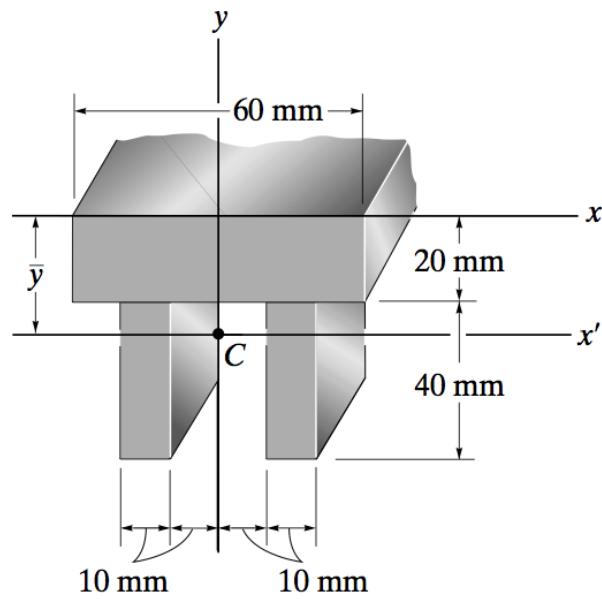

Figure Q3-(c)

(5 marks)

#### Question 4

- (a) A car is traveling at 15m/s, when the traffic light 50 m ahead turns yellow.

i) Determine the required constant deceleration of the car and,

(2 marks)

ii) the time required to stop the car at the light.

(2 marks)

- (b) The snowmobile moves along a straight course according to the  $v$ - $t$  graph in Figure Q4-(b). Construct the  $s$ - $t$  and  $a$ - $t$  graphs for the same 50-s time interval. When  $t = 0$ ,  $s = 0$ .

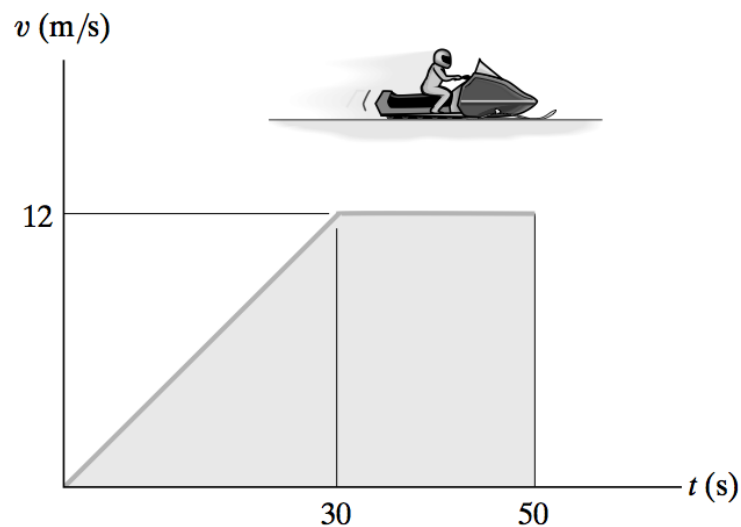

Figure Q4-(b)

(6 marks)

- (c) A worker uses high-pressure water to clean the inside of a long drainpipe as shown in Figure Q4-(c). If the water is discharged with an initial velocity of 11.5 m/s, determine

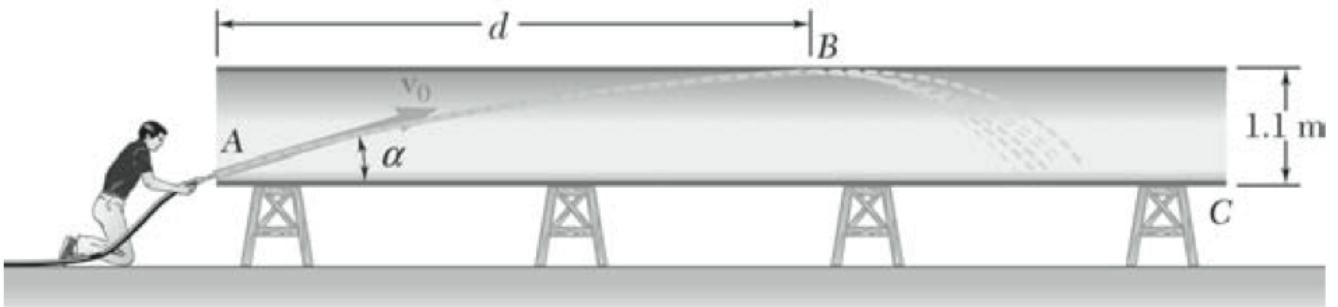

Figure Q4-(c)

- i) the corresponding angle  $\alpha$ , and  
(4 marks)
  - ii) the distance  $d$  to the farthest Point **B** on the top of the pipe that the worker can wash from his position at **A**.  
(4 marks)
- (d) The acceleration of a particle is defined by the relation  $a = -\frac{k}{x}$ . It has been experimentally determined that when velocity,  $v = 15$  m/s then  $x = 0.6$  m and that velocity,  $v = 9$  m/s then  $x = 1.2$  m. Determine
- i) the velocity of the particle when  $x = 1.5$  m,  
(4 marks)
  - ii) the position of the particle,  $x$  when its velocity is zero.  
(3 marks)

**Question 5**

- (a) Starting from rest, the motorboat in Figure Q5-(a) travels around the circular path,  $\rho = 50$  m, at a speed  $v = (0.2t^2)$  m/s, where  $t$  is in seconds.

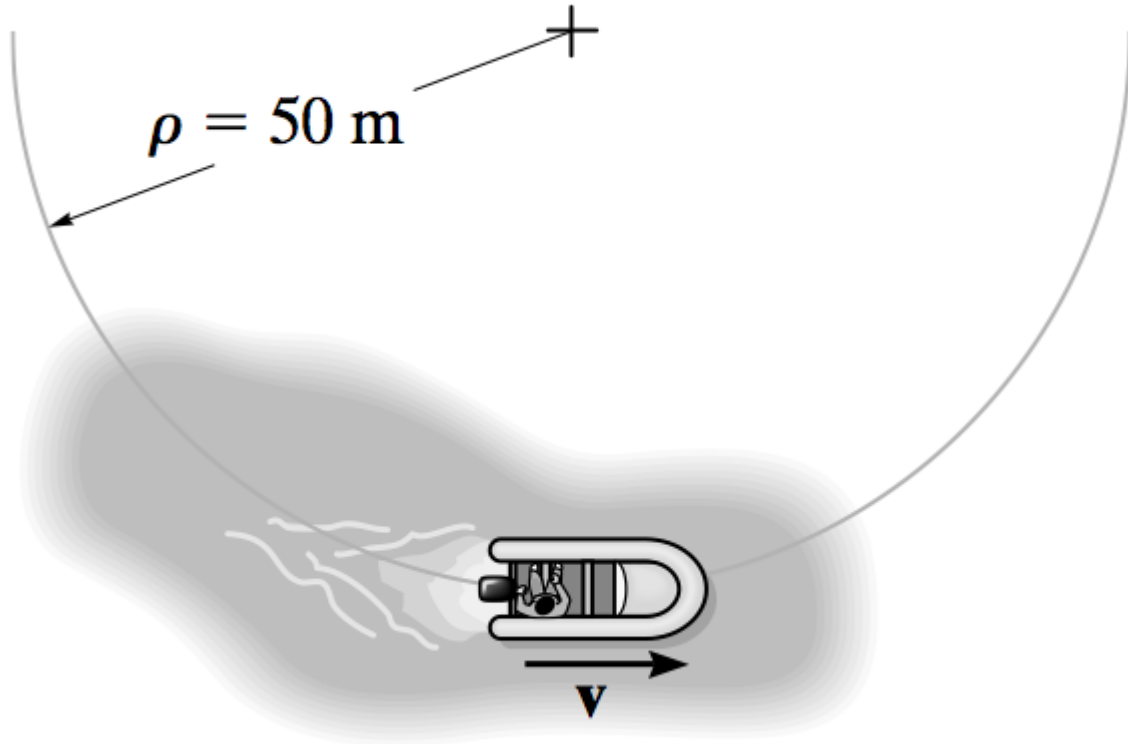

Figure Q5-(a)

- i) Determine the magnitudes of the boat's velocity when  $t = 3$  s, (2 marks)
- ii) Calculate the acceleration at the instant  $t = 3$  s. (4 marks)
- (b) A 200-kg satellite is in a circular orbit 1500 km above the surface of Venus. The acceleration due to the gravitational attraction of Venus at this altitude is  $5.52 \text{ m/s}^2$ . Determine the magnitude of the linear momentum of the satellite knowing that its orbital speed is  $23.4 \times 10^3 \text{ km/h}$ . (3 marks)
- (c) A hockey player hits a puck so that it comes to rest in 9 s after sliding 30 m on the ice.
- i) Assume that the ice puck decelerate uniformly, determine the initial velocity of the puck, (2 marks)
- ii) Calculate the coefficient of kinetic friction between the puck and the ice. (5 marks)

- (d) The diesel engine of a 400-Mg train increases the train's speed uniformly from rest to 10 m/s in 100 s along a horizontal track.
- State a general equation represents the principle of work and energy.  
(1 mark)
  - Determine the average power developed.  
(4 marks)
- (e) The 28-Mg bulldozer is originally at rest. Determine its speed when  $t = 4$  s if the horizontal traction  $F$  varies with time as shown in Figure Q5-(e).

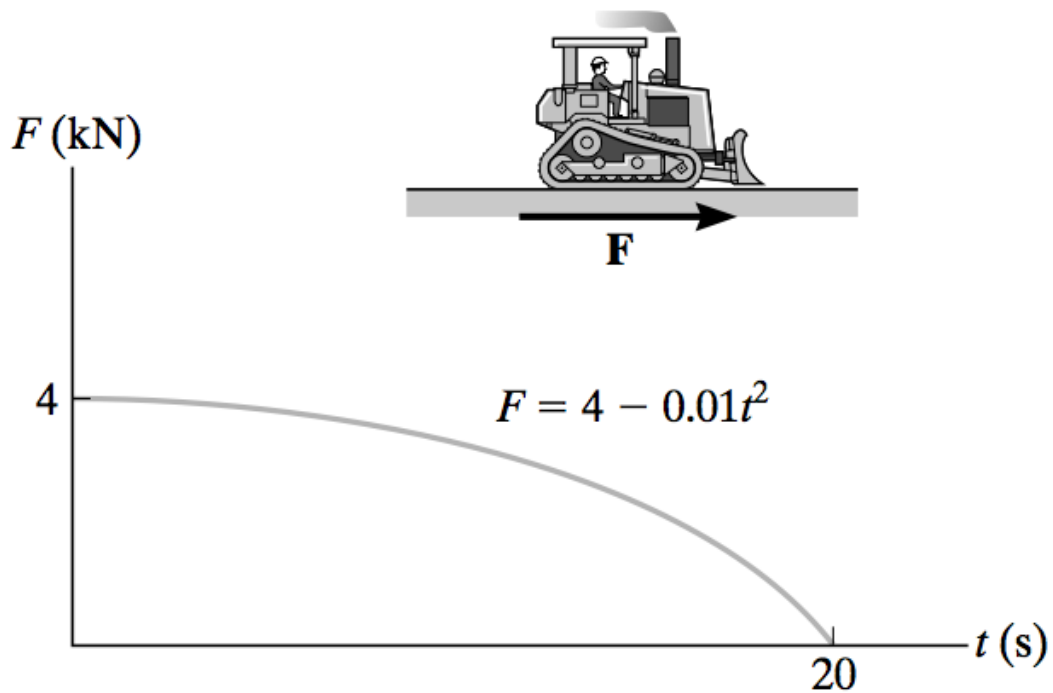

Figure Q5-(e)

(4 marks)