

FINAL
Examination Paper

(COVER PAGE)

Session : April 2019

Programme : Foundation in Science (CFSI)

Course : **BIO1203 : BIOLOGY 1**

Date of Examination : 26 July 2019 (Friday)

Time : 2:00PM – 4:00PM Reading Time : Nil

Duration : 2 hours

Special Instructions :

This paper consists of **FIVE (5)** questions. Answer any **FOUR (4)** questions in the answer booklet provided. All questions carry equal marks.

Materials permitted :

Non-Programmable Calculator

Materials provided :

Answer Booklet

Examiner(s) : **Dr. Khor Soo Ping**

Moderator : **Assoc. Prof. Dr. Sreeramanan Subramaniam**

This paper consists of 10 printed pages, including the cover page.

INTI INTERNATIONAL COLLEGE PENANG

FOUNDATION IN SCIENCE (CFSI)

BIO1203: BIOLOGY 1

FINAL EXAMINATION: APRIL 2019 SESSION

Instructions: This paper consists of **FIVE (5)** questions. Answer any **FOUR (4)** question in the answer booklet provided. All questions carry equal marks.

Question 1

- (a) Define emergent properties. (1 marks)
- (b) (i) List the procedures that involves in the modern scientific method. (3 marks)
- (ii) An experiment is performed on plants to see how different liquids affect plant growth. Each plant in the experiment is given a different liquid; water, apple juice, and milk. Each plant has the same amount of soil, same amount of sunlight, and the same amount of liquid. In this investigation, identify the control, independent and dependent variable. (3marks)
- (c) Low density of ice is an important life supporting properties of water. Figure Q1(c) illustrates the molecular structure of water molecules in solid (ice) and liquid phase.

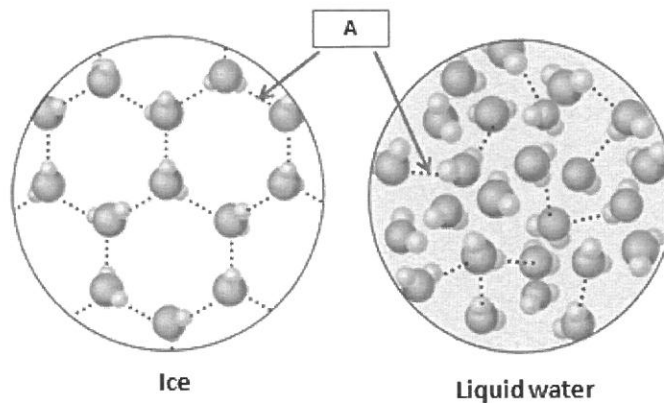
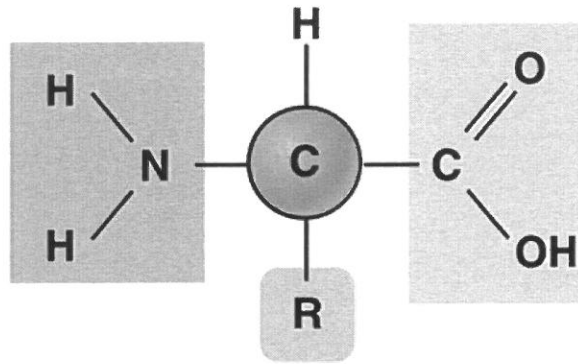

Figure Q1(c).

- (i) Name the bond in **A**. (1 mark)
- (ii) Explain why ice is less dense than water, and how do aquatic organisms benefits in this phenomenon. (5 marks)
- (d) List **THREE (3)** examples of polysaccharides and describe their functions. (6 marks)

(e) Figure Q1(e) shows the monomer of protein.



Monomer of protein

Figure Q1(e)

- (i) Name the monomer of protein in Figure Q1(e). (1 mark)
- (ii) Name the functional group(s) of monomer presents in Figure Q1(e). (1 mark)
- (iii) Using the monomer of protein as an example, explain the chemical reaction of building a polymer from a set of monomers. (4 marks)

Question 2

- (a) The Figure Q2(a) shows cells in various phases of the cell cycle. Note that the cells are not arranged in the order in which the cell cycle occurs.

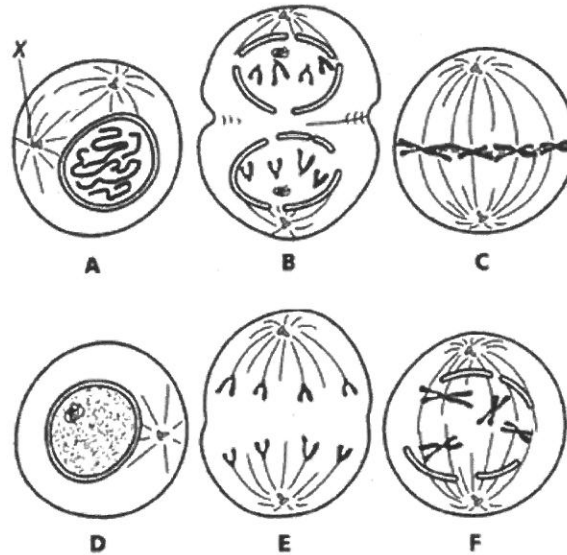

Figure Q2(a)

- (i) Name the structure labelled **X** and state its function. (2 marks)
- (ii) List the correct sequence of mitosis event using letters (**A** to **F**). (3 marks)
- (iii) Name the stage of mitosis shown in **F**. Explain the important events in this phase. (3 marks)
- (iv) State **ONE (1)** similarity and **ONE (1)** difference between mitosis and meiosis. (2 marks)
- (b) Define incomplete dominance and codominance. (2 marks)
- (c) A human female "carrier" who is heterozygous for the recessive, sex-linked trait causing red-green colour blindness, marries a normal male. What proportion of their female children will have red-green colour blindness? What proportion of their male children will have red-green colour blindness?
Key: Normal = A, red-green colour blindness = a (5 marks)

- (d) Complete the following dihybrid cross for summer squash plant's traits. The plant produces fruits that are either white or yellow in colour and are either shaped like a disc or a sphere. The dominant phenotypes are white and disc shaped fruits. Using the symbols **A** for white, **a** for yellow, **B** for disc and **b** for sphere, draw a Punnett square to show the genotypes and phenotypes of **all** offspring if a white and disc-shaped fruit plant is self fertilized, and assumed heterozygous for both genes. Include fraction of each phenotype. (8 marks)

Question 3

- (a) Figure Q3(a) illustrates an incomplete cell structures of plant.

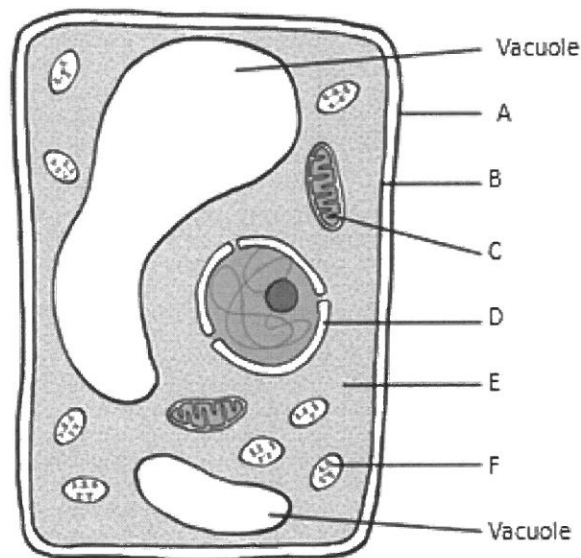

Figure Q3(a)

- (i) Identify structure **A**, **B**, **C**, **D**, **E**, **F** and state one function for **A**, **B**, **C** and **D**. (10 mark)
- (ii) There are a few missing structures in the plant cell which are important for manufacturing lipids and proteins, distribution and also breakdown of macromolecules. List any **TWO** (2) cell structures with these functions that are not included in the figure. (2 mark)

(b) Figure Q3(b) shows an inhibition of enzyme.

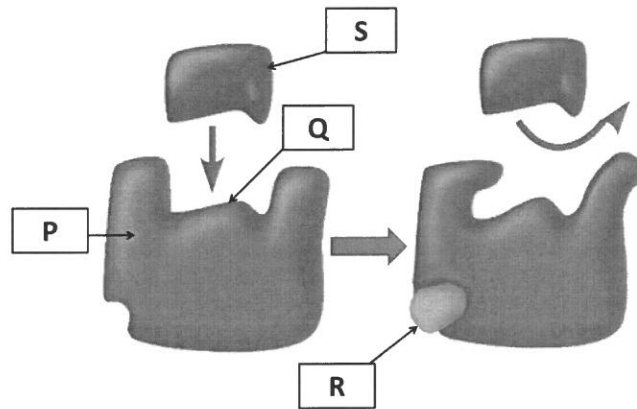

Figure Q3(b)

(i) Identify the structures labeled **P**, **Q**, **R** and **S**. (4 marks)

(ii) Explain how enzyme activity in cell is regulated by the mechanism with **R**. (4 marks)

(c) Figure Q3(c) below illustrates a reaction with and without an enzyme. Which curve represents the enzyme-catalyzed reaction? Briefly explain how enzymes speed up the cell's chemical reaction?

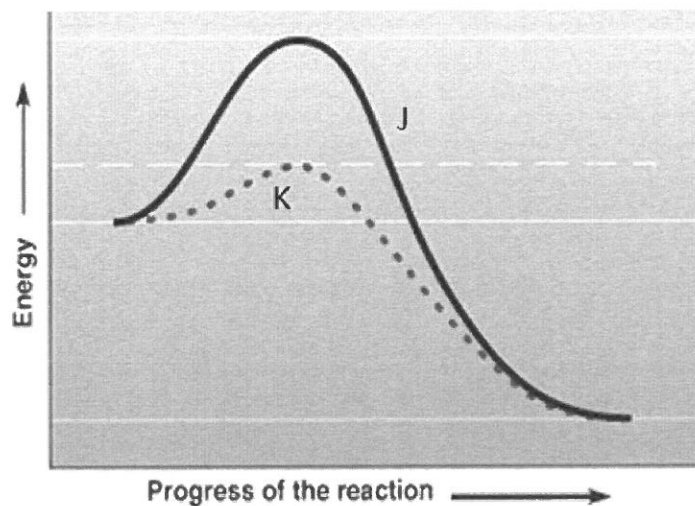

Figure Q3(c)

(2 marks)

(d) With an image of phospholipids, briefly explain why phospholipids are made from unsaturated fatty acids that have kinks in their tails. (3 marks)

(3 marks)

Question 4

(a) Figure Q4(a) shows diagram of main stages in aerobic respiration.

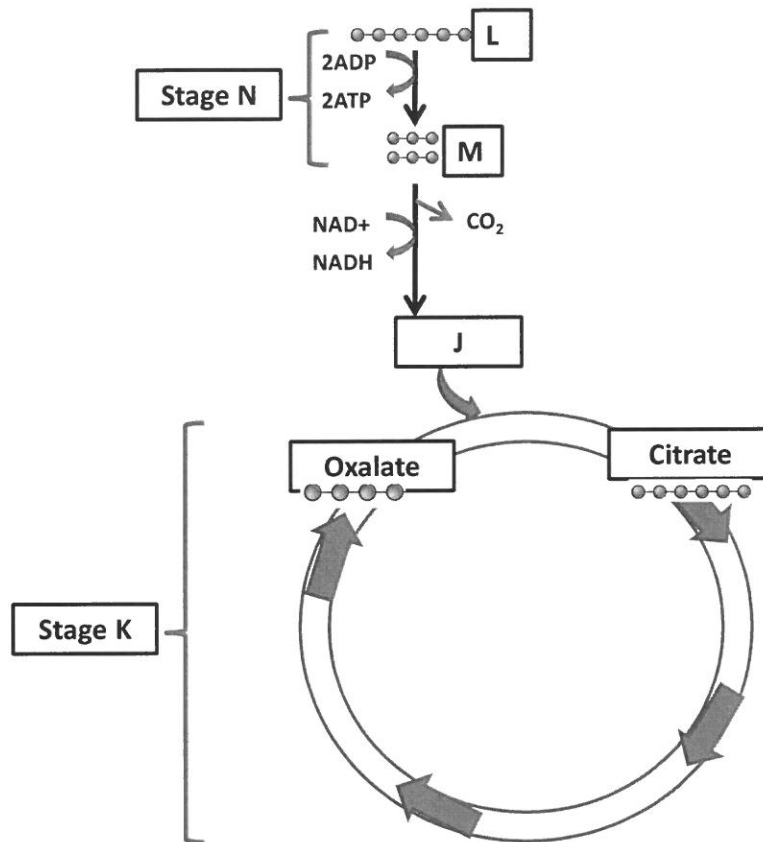

Figure Q4(a)

- (i) Write the summary equation for cellular respiration. (2 marks)
 - (ii) Name the label L, M, N, and K. (4 marks)
 - (iii) Where do stage N and K takes place in the cell? (2 marks)
 - (iv) Identify J and state the role of J in stage K. (2 marks)
- (b) Anaerobic respiration occurs primarily in muscle cells when human perform high intensity activity. Describe what happen during anaerobic solution. (2 marks)

(c) Figure Q4(c) illustrates the light-dependent reaction of photosynthesis.

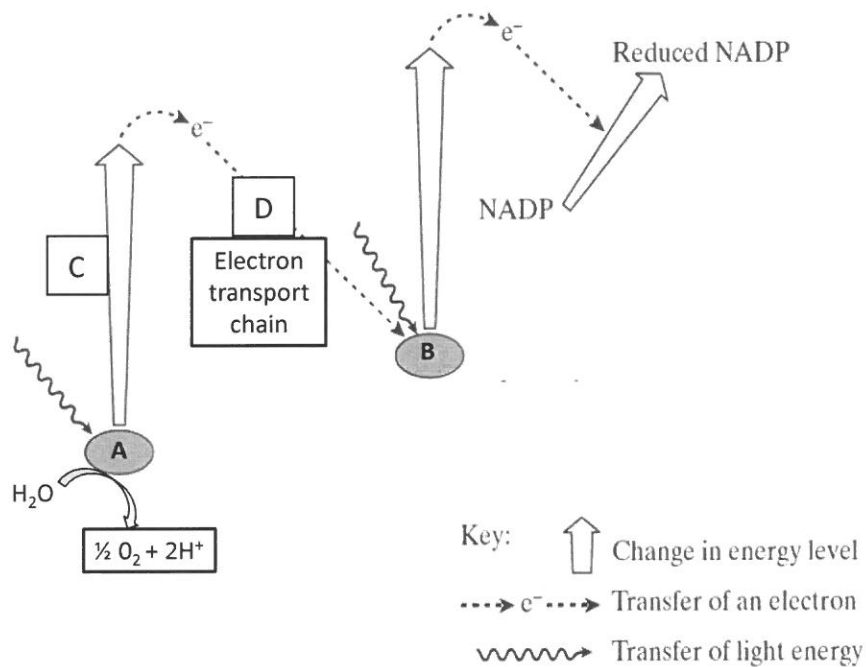

Figure Q4(c)

- (i) Write the summary equation of photosynthesis. (2 marks)
- (ii) Where does the light-dependent reaction take place in a chloroplast? (1 mark)
- (iii) What are the products of light dependent reactions? (3 marks)
- (iv) What happen to the oxygen atom and hydrogen ion after water splits in conjunction with activities in **A**? (2 marks)
- (v) When light energy strikes **A**, it triggers light-dependent photosynthesis. Elaborate events happened in stage **C** and **D**. (5 marks)

Question 5

(a) Figure Q5(a) below shows part of the DNA molecule.

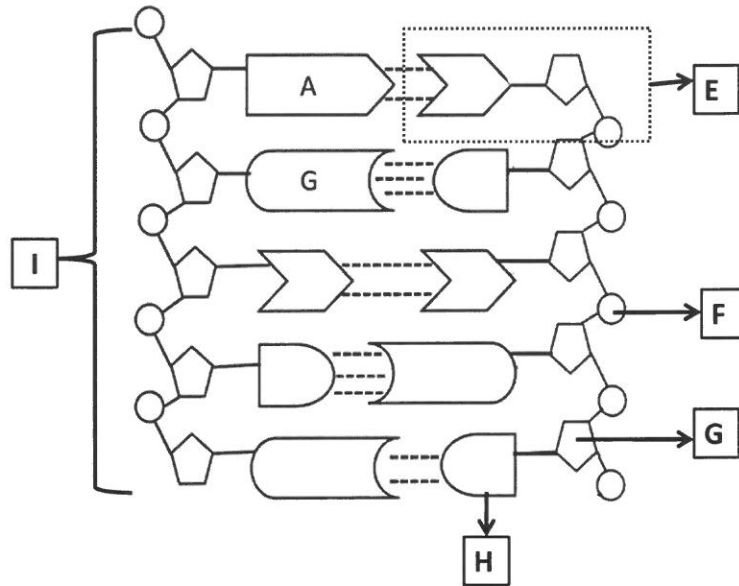

Figure Q5(a)

- (i) Name the structures labeled **E**, **F**, **G** and **H**. (4 marks)
- (ii) How are two strands of DNA molecule held together? (1 mark)
- (iii) Structure **I** refers to a segment of nucleotide sequence in a DNA molecule that codes for a protein. It is known as _____. (1 mark)
- (iv) An analysis of a molecule of DNA showed that thymine accounted for 10 % of the content of the nitrogenous bases. Calculate the percentage of cytosine in the molecule. Show your working. (2 marks)

(b) The letters below represent part of a DNA sequence for a gene encodes for a certain protein.
CCT TAC GAA CGA

- (i) Write the nucleotide sequence of the other strand of DNA. (1 mark)
- (ii) Transcribe the DNA sequence mentioned in (i) into RNA. (1 mark)

- (iii) The table Q5(b) shows the codons and the specified acid amino. Write the sequence of amino acids that is produced by the translation of the RNA mentioned in (ii).

Three-letter codons of messenger RNA, and the amino acids specified by the codons			
AAU } Asparagine	CAU } Histidine	GAU } Aspartic acid	UAU } Tyrosine
AAC } Asparagine	CAC } Histidine	GAC } Aspartic acid	UAC } Tyrosine
AAA } Lysine	CAA } Glutamine	GAA } Glutamic acid	UAA } Stop
AAG } Lysine	CAG } Glutamine	GAG } Glutamic acid	UAG } Stop
ACU } Threonine	CCU } Proline	GCU } Alanine	UCU } Serine
ACC } Threonine	CCC } Proline	GCC } Alanine	UCC } Serine
ACA } Threonine	CCA } Proline	GCA } Alanine	UCA } Serine
ACG } Threonine	CCG } Proline	GCG } Alanine	UCG } Serine
AGU } Serine	CGU } Arginine	GGU } Glycine	UGU } Cysteine
AGC } Serine	CGC } Arginine	GGC } Glycine	UGC } Cysteine
AGA } Arginine	CGA } Arginine	GGA } Glycine	UGA } Stop
AGG } Arginine	CGG } Arginine	GGG } Glycine	UGG } Leucine
AUU } Isoleucine	CUU } Leucine	GUU } Valine	UUU } Phenylalanine
AUC } Isoleucine	CUC } Leucine	GUC } Valine	UUC } Phenylalanine
AUA } Isoleucine	CUA } Leucine	GUA } Valine	UUA } Leucine
AUG } Methionine	CUG } Leucine	GUG } Valine	UUG } Leucine

Table Q5(b)

(1 mark)

- (c) Describe the flow of genetic information from DNA to protein expression, and state where the reaction takes place. (2 marks)
- (d) Explain how a large number of copies of DNA can be produced using the polymerase chain reaction (PCR). (5 marks)
- (e) Figure Q5(e) shows two different types of mutation that occur in a gene. Identify the type of mutation for both mutation 1 and 2 and explain the consequences of each.

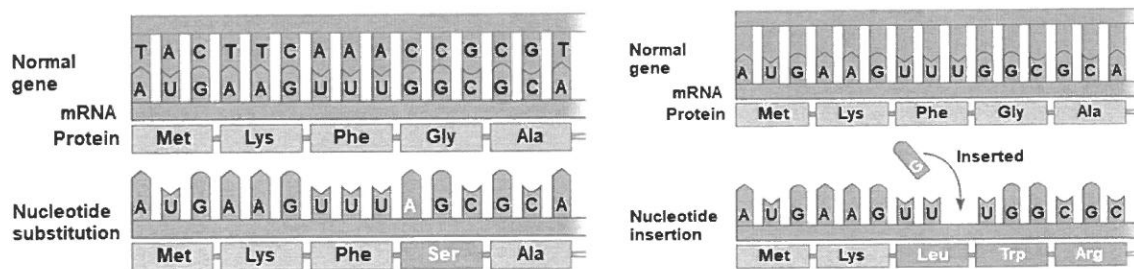

Figure Q5(e)

(4 marks)

- (f) Explain **THREE (3)** mechanisms of bacteria gene transfer.

(3 marks)

~ The End ~